

# APPLICATION NOTE

PWR220 Series

Networking and Communications

Use of PWR Power Resistors in Telecom Power Supplies



## Introduction

Communications equipment for broadband and wireless infrastructure as well as networking equipment in central offices requires significant amounts of DC power. Very often a rectifier module can be used as a building block in a distribution system where power can be increased by adding more modules. Scalable systems can be visualized in the below image of a cellular phone network base station.

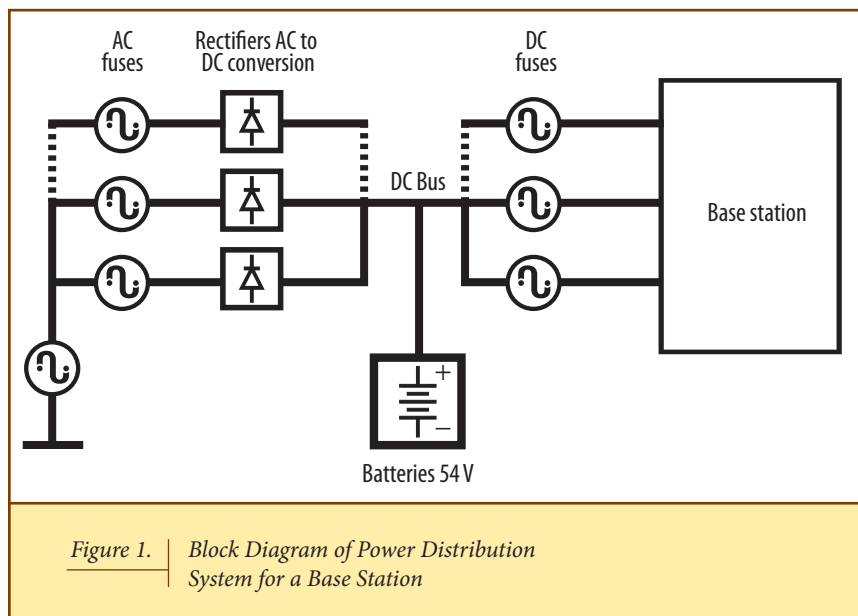

Modular rectifiers will provide a rated output in power (KW) and efficiency. If one rectifier were to fail in the field it could be replaced without having to shut down the whole system. Chargeable battery banks provide back up power should the connection to the electricity supply be interrupted.



**Application**

Figure 2 represents the schematic of part of a power supply showing an inverter and rectifier for telecom applications. The combined use of a resistor and capacitor (RC) snubber circuit protects the semiconductors from high unclamped inductive energy levels associated with fast switching of currents. The capacitor has the effect of clamping the voltage spike to a non-dangerous level, while the resistor dissipates the high amount of energy.

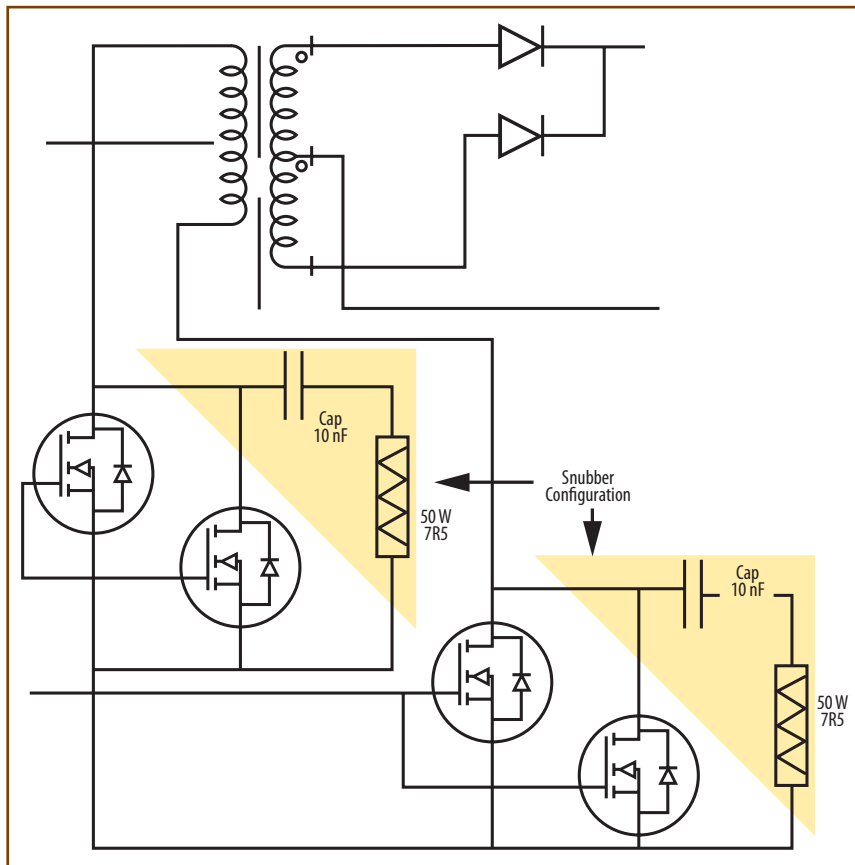
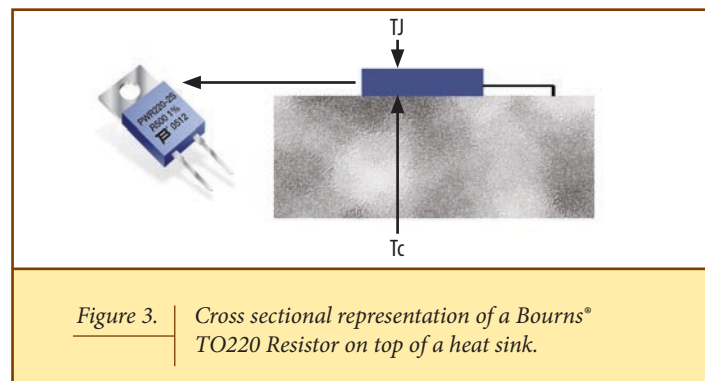

Figure 2. Section of power supply where the signal is inverted using high power MOSFETs (see above) connected across snubber configurations before being stepped up (XTFO) and rectified to provide DC power.



Planar thick film power resistors are a good solution as a snubber resistor in this application. Planar resistors have low inductance which is an inherent advantage in circuits using high voltage semiconductors that are switching at frequencies in the megahertz region. The inductance of a circuit pushes AC signals passing through it out of phase; the lowest possible inductance minimizes this effect. This eventually means greater loss and less efficiency in the rectifier. Planar thick film resistors are also able to dissipate high amounts of power once mounted on a suitable heat sink. Depending on the power rating in the application, it is possible to specify the thermal resistance of the heat sink required to keep the surface temperature of the resistor ( $T_J$ ) and the case temperature of the resistor ( $T_c$ ) within the specified limits.



To achieve 30 watts of power, for example, a heat sink with a thermal resistance of  $R\theta H$  is required.  $R\theta H$  can be calculated from the following formula:  $(P = T_J - T_c / (R\theta JC + R\theta H))$ .

### Where

- A)  $R\theta JC$  is the thermal resistance of the resistor (2.1 °C/watt as given in the datasheet of PWR220)
- B)  $T_J$  is the temperature measured on the film of the resistor (maximum 155 °C)
- C)  $T_c$  is the temperature at the junction between the copper flange and the heat sink (maximum 50 °C).

Under these conditions a heat sink with a thermal resistance of no more than 1.4 °C/watt would have to be used.

## PWR220 Series

## Networking and Communications

## Use of PWR Power Resistors in Telecom Power Supplies



The PWR220 series is available in both through-hole and surface mount formats. Surface mount formats are very popular as more assembly lines are switching to automated pick and place methods. A suitable heat sink located beneath the circuit board and connected to it using solder filled vias underneath the resistor is very important in order to dissipate as much heat as possible.

The PWR220-2FA series is fully RoHS compliant and compatible with lead free soldering profiles. The Bourns recommended profile is shown below.

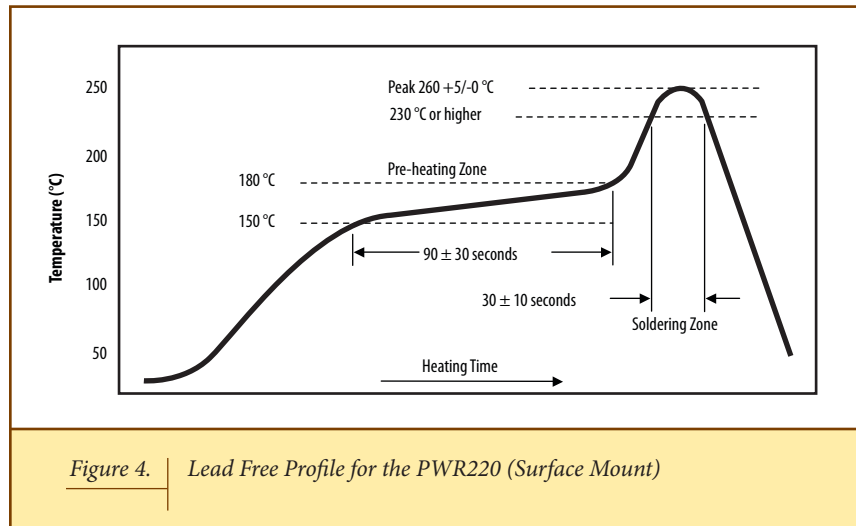

For more information on the PWR220 and other resistive products from Bourns, please visit

[www.bourns.com](http://www.bourns.com)

**BOURNS®**

**Americas:** Tel +1-951 781-5500  
Fax +1-951 781-5700

**Europe:** Tel +41-(0)41 768 55 55  
Fax +41-(0)41 768 55 10

**Asia-Pacific:** Tel +886-2 256 241 17  
Fax +886-2 256 241 16