

Features

- RoHS compliant*
- ESD protection >25 kV
- Surge protection
- Low capacitance

Applications

- IC supply line protection
- MOSFET gate protection
- Control line protection
- Low frequency I/O line protection

ChipGuard® CG0805MLA Series - ESD Protector Array

General Information

The ChipGuard® CG0805MLA series has been designed to provide a competitive solution for applications where capacitance of the ESD protector is less critical. General ESD applications in end products such as computers, analog modems and PDAs include IC supply lines, MOSFET gate protection, and low frequency digital and control lines.

The ChipGuard® CG0805MLA quad device is designed to protect equipment to IEC61000-4-2, Level 4 (± 8 kV Contact / ± 15 kV Air Discharge) ESD specification.

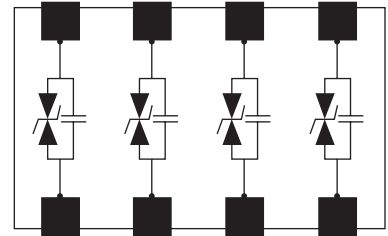

Electrical & Thermal Characteristics @ TA = 25 °C (unless otherwise noted)

Parameter	Symbol	CG0805MLA-5.5ME	CG0805MLA-18KE	Unit
Maximum AC Working Voltage @ 10 μ A Max.	V_{RMS}	4	14	V
Maximum DC Working Voltage @ 10 μ A Max.	V_{DC}	5.5	18	V
Minimum Resistance @ 3.3 VDC	I_R	10		Megohms
Maximum Peak Current @ 8/20 μ S Pulse	I_S	10	5	A
Maximum Transient Energy @ 10/1000 μ S Pulse	W_{Max}	0.01		Joules
Nominal Breakdown Voltage @ 1 mA	V_{BR}	12	28	V
Breakdown Voltage Tolerance	% V_{BR}	20	10	%
Maximum Clamping Voltage @ 1 A 8/20 μ S Pulse	V_C	28	58	V
Typical Capacitance @ 1 VRMS 1 kHz	C_{O1}	36	17	pF
Typical Capacitance @ 1 VRMS 1 MHz	C_{O2}	33	15	pF
Maximum Response Time	R_T	1		ns
ESD Protection: Per IEC 61000-4-2 Min. Contact Discharge (>100 Repts) Min. Air Discharge (>100 Repts)			± 8 ± 15	kV kV
Operating Temperature	T_{OPR}	-40 to +85		$^{\circ}$ C
Storage Temperature	T_{STG}	-40 to +85		$^{\circ}$ C

*RoHS Directive 2002/95/EC Jan 27 2003 including Annex.
Specifications are subject to change without notice.
Customers should verify actual device performance in their specific applications

Product Dimensions

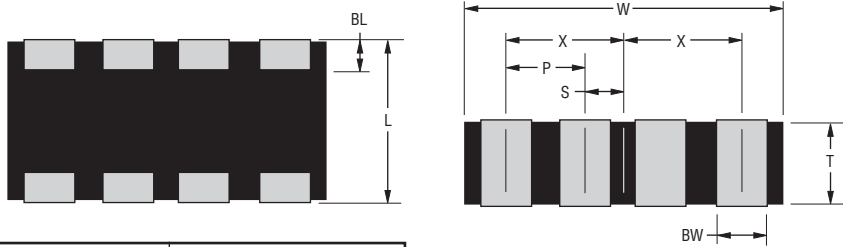

DIMENSIONS: $\frac{\text{MM}}{\text{(INCHES)}}$

Dimension	CG0805 Series
L	$\frac{1.25 \pm 0.20}{(0.049 \pm 0.008)}$
W	$\frac{2.00 \pm 0.20}{(0.080 \pm 0.008)}$
T	$\frac{0.90}{(0.035) \text{ MAX.}}$
BW	$\frac{0.20 \pm 0.10}{(0.008 \pm 0.004)}$
BL	$\frac{0.20 \pm 0.10}{(0.008 \pm 0.004)}$
P	$\frac{0.50}{(0.020)}$
X	$\frac{0.75 \pm 0.10}{(0.029 \pm 0.004)}$
S	$\frac{0.25 \pm 0.10}{(0.009 \pm 0.004)}$

Recommended Pad Layout

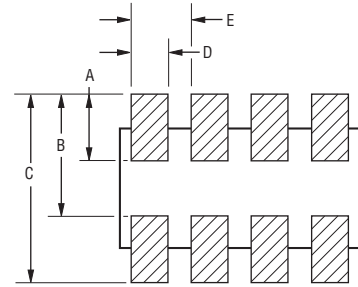

Dimension	CG0805 Series
A	$\frac{0.64}{(0.025)}$
B	$\frac{1.27}{(0.050)}$
C	$\frac{1.91}{(0.075)}$
D	$\frac{0.28}{(0.011)}$
E	$\frac{0.51}{(0.020)}$

Solder Reflow Recommendations

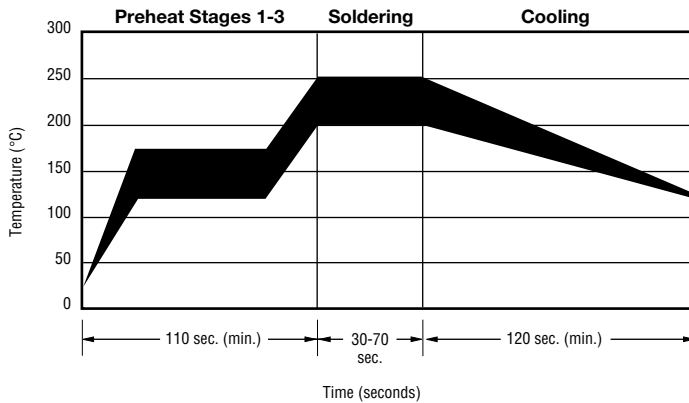

A	Stage 1 Preheat	Ambient to Preheating Temperature	30 s to 60 s
B	Stage 2 Preheat	140 °C to 160 °C	60 s to 120 s
C	Stage 3 Preheat	Preheat to 200 °C	20 s to 40 s
D	Main Heating	200 °C	60 s to 70 s
		210 °C	55 s to 65 s
		220 °C	50 s to 60 s
		230 °C	40 s to 50 s
		240 °C	30 s to 40 s
E	Cooling	200 °C to 100 °C	1 °C/s to 4 °C/s

- This product can be damaged by rapid heating, cooling or localized heating.
- Heat shocks should be avoided. Preheating and gradual cooling recommended.
- Excessive solder can damage the device. Print solder thickness of 150 to 200 um recommended.
- Solder gun tip temperature should be kept below 280 °C and should not touch the device directly. Contact should be less than 3 seconds. A solder gun under 30 watts is recommended.

ChipGuard® CG0805MLA Series - ESD Protector Array

BOURNS®

Packaging Dimensions

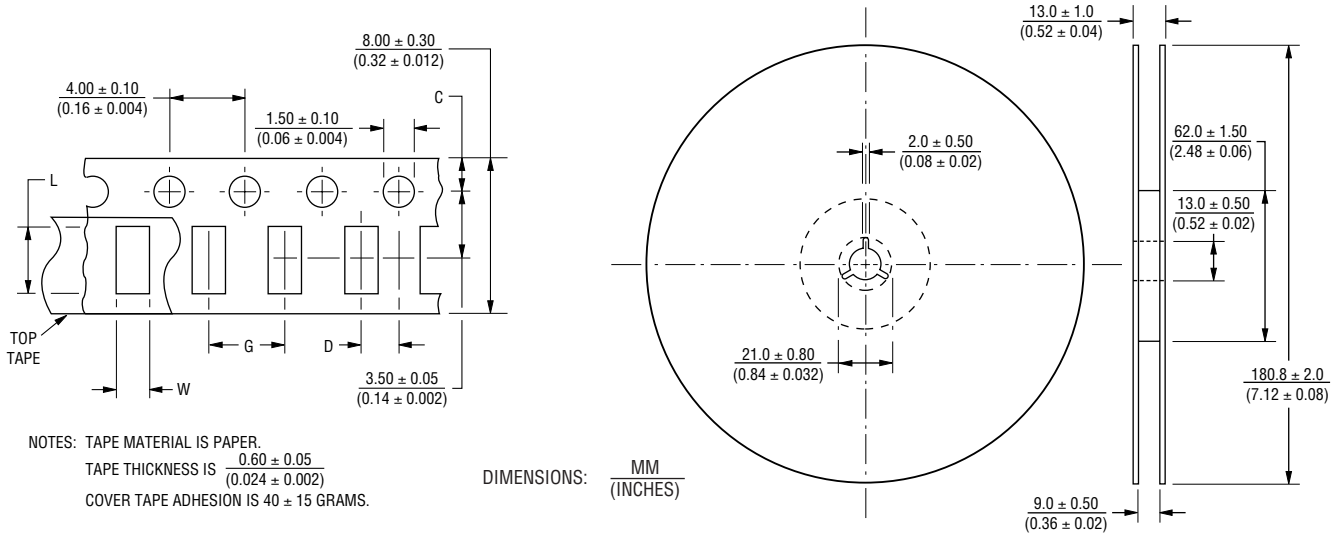

Dimension	CG0805 Series
C	$\frac{1.75 \pm 0.10}{(0.069 \pm 0.004)}$
D	$\frac{2.00 \pm 0.05}{(0.080 \pm 0.002)}$
L	$\frac{2.40 \pm 0.20}{(0.094 \pm 0.008)}$
W	$\frac{1.65 \pm 0.20}{(0.065 \pm 0.008)}$
G	$\frac{4.00 \pm 0.10}{(0.16 \pm 0.004)}$

How to Order

CG 0805 - MLA 18 K E

ChipGuard®
 Product Designator
 Package Option
 0805 = 0805 Package
 Model Series
 MLA = Standard Capacitance
 Working Peak Voltage
 18 = 18 V
 5.5 = 5.5 V
 Tolerance
 K = 10 %
 M = 20 %
 Tape & Reel Packaging
 E = 4,000 pcs. per reel



Asia-Pacific: TEL +886-2 25624117 • FAX +886-2 25624116
Europe: TEL +41-41 7685555 • FAX +41-41 7685510
The Americas: TEL +1-951 781-5500 • FAX +1-951 781-5700
www.bourns.com