

\*ROHS COMPLIANT

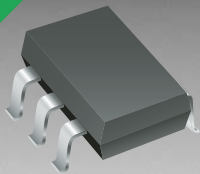

**BOURNS®**

## Features

- Lead free device (RoHS Compliant\*)
- Protects 4 lines
- ESD & EFT protection
- Low capacitance <5 pF

## Applications

- Portable electronics
- Cell phones
- Video/graphics card
- USB 2.0 interface
- Sensor interface

# CDSOT23-SR208 – Steering Diode Array

## General Information

The markets of portable communications, computing and video equipment are challenging the semiconductor industry to develop increasingly smaller electronic components.

Bourns offers Transient Voltage Suppressor Array diodes for EFT and ESD protection applications, in compact chip package SOT23-6 size format. Bourns® Chip Diodes conform to JEDEC standards, are easy to handle on standard pick and place equipment and their flat configuration minimizes roll away.

The Bourns® device will meet IEC 61000-4-2 (ESD) and IEC 61000-4-4 (EFT) requirements.

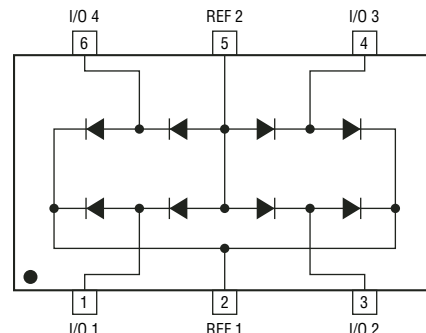

## Electrical Characteristics (@ T<sub>A</sub> = 25 °C Unless Otherwise Noted)

Parameter	Symbol	Min.	Nom.	Max.	Unit
Repetitive Peak Forward Current (t <sub>p</sub> = 5 μs, F = 50 KHz)	I <sub>FRM</sub>			700	mA
Continuous Power Dissipation	P <sub>PC</sub>			500	mW
Forward Voltage @ 50 mA	V <sub>F</sub>			1.2	V
Repetitive Peak Reverse Voltage @ 10 μA	V <sub>RRM</sub>			20	V
Reverse Leakage Current @ V <sub>RRM</sub> 5V	I <sub>R</sub>			1	μA
Capacitance <sup>1</sup>	C <sub>J(SD)</sub>			5	pF
Forward Surge Rating (1/20 s @ 25 °C, I <sub>F</sub> = 10 mA)	V <sub>F</sub>			1.5	V

Note:

1. Apply a 5 V bias between pins 2 (REF 1) to pin 5 (REF 2). Measure C<sub>j</sub> between any I/O pins to pin 5 (REF 2) and divide by two.

## Thermal Characteristics (@ T<sub>A</sub> = 25 °C Unless Otherwise Noted)

Parameter	Symbol	Min.	Nom.	Max.	Unit
Operating Temperature	T <sub>J</sub>	-55	+25	+150	°C
Storage Temperature	T <sub>STG</sub>	-55	+25	+150	°C

\*RoHS Directive 2002/95/EC Jan 27 2003 including Annex.

Specifications are subject to change without notice.

Customers should verify actual device performance in their specific applications.

# CDSOT23-SR208 – Steering Diode Array

**BOURNS®**

## Mechanical Characteristics

This is a molded JEDEC SOT23-6 package with lead free 100 % Tin (Sn) on the lead frame. It weighs approximately 15 mg and has a flammability rating of UL 94V-0.

## Product Dimensions

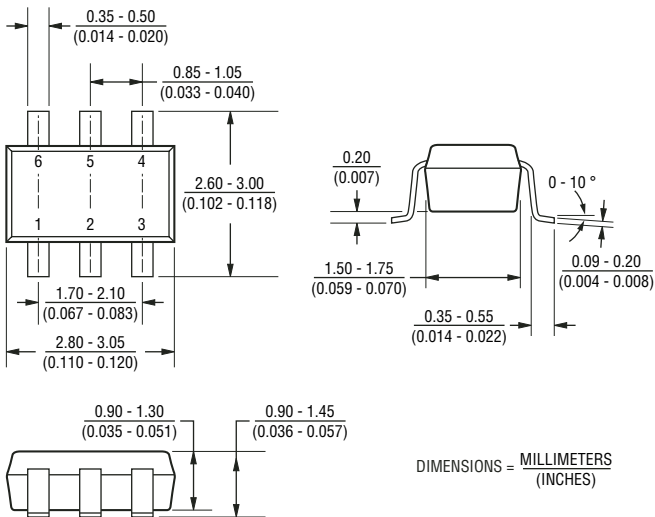

## Recommended Footprint

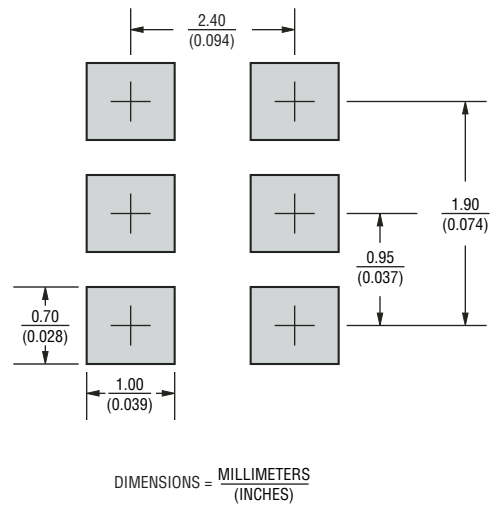

## Packaging Information

The product will be dispensed in Tape and Reel format (see diagram below).

TOP SIDE VIEW  
(INTO COMPONENT POCKET)

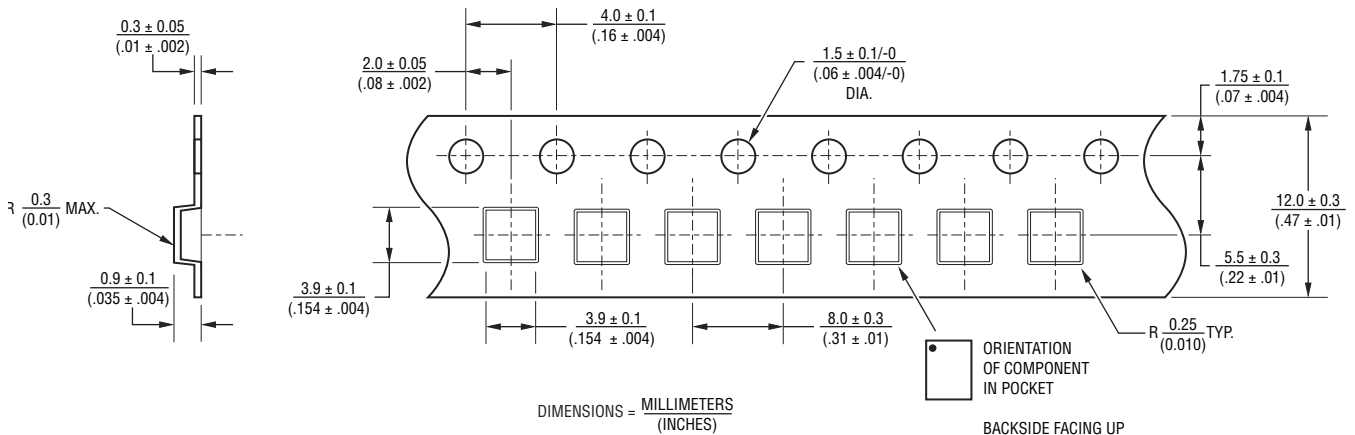

Devices are packed in accordance with EIA standard RS-481-A and specifications shown here.

# CDSOT23-SR208 – Steering Diode Array



## Performance Graphs

### Peak Forward Current vs Forward Voltage



### Low Forward Current vs Forward Voltage

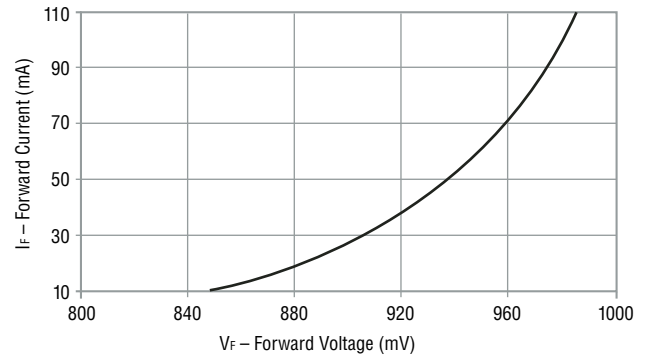

### Block Diagram

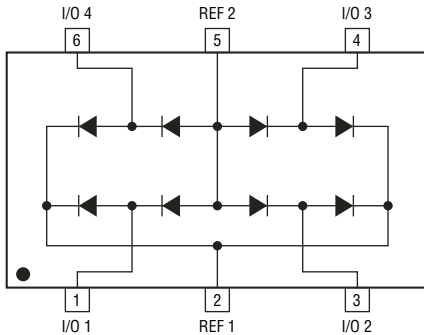

### Power Derating Curve

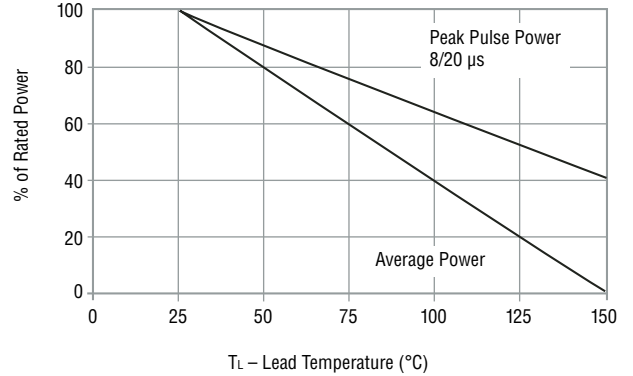

### How To Order

**CD SOT23 - SR 208**

Common Code \_\_\_\_\_  
 CD = Chip Diode

Package \_\_\_\_\_  
 SOT23 = SOT23-6 Package

Model \_\_\_\_\_  
 SR = Steering Diode

Model Number \_\_\_\_\_  
 208

### Typical Part Marking

CDSOT23-SR208 ..... **PSB**



*Reliable Electronic Solutions*

#### Asia-Pacific:

Tel: +886-2 2562-4117 • Fax: +886-2 2562-4116

#### Europe:

Tel: +41-41 768 5555 • Fax: +41-41 768 5510

#### The Americas:

Tel: +1-951 781-5500 • Fax: +1-951 781-5700

[www.bourns.com](http://www.bourns.com)