

Features

- Lead free as standard*
- ESD protection 30 kV max.
- Low capacitance ~ 1.0 pF
- Protects 1 line
- Uni/bidirectional configuration

Applications

- HDMI 1.4
- Digital Visual Interface (DVI)
- USB 3.0 / USB OTG
- Memory protection
- SIM card ports

CDSOD323-TxxLC - TVS Diode Series

General Information

The markets of portable communications, computing and video equipment are challenging the semiconductor industry to develop increasingly smaller electronic components.

Bourns offers Transient Voltage Suppressor Diodes for surge and ESD protection applications in SOD323 package size format. The Transient Voltage Suppressor Diode series offers a choice of voltage types ranging from 3 V to 24 V in a unidirectional or bidirectional configuration.

Bourns® Chip Diodes conform to JEDEC standards, are easy to handle on standard pick and place equipment and their flat configuration minimizes roll away. The Bourns® device meets IEC 61000-4-2 (ESD), IEC 61000-4-4 (EFT) and IEC 61000-4-5 (Surge) requirements.

This device is not recommended for use in VDSL applications.

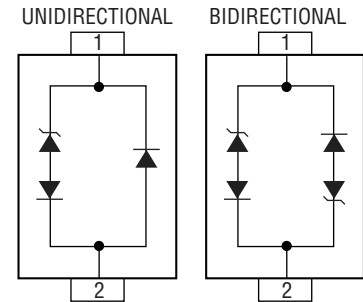

Electrical & Thermal Characteristics (@ T_A = 25 °C Unless Otherwise Noted)

| Parameter | Symbol | Value | Unit |
|--|------------------|-------------|------|
| Unidirectional Peak Pulse Power (t _p = 8/20 μs) | P _{PP} | 350 | W |
| Bidirectional Peak Pulse Power (t _p = 8/20 μs) | P _{PP} | 250 | W |
| Operating Temperature | T _L | -55 to +150 | °C |
| Storage Temperature | T _{STG} | -55 to +150 | °C |
| ESD Protection (per IEC 61000-4-2) | ESD | ±8 | kV |
| Contact - Min. | | ±30 | |
| Air - Min. | | ±15 | |
| Air - Max. | | ±30 | |

| Parameter | Symbol | CDSOD323- | | | | | | | | Unit |
|--|-----------------|-------------|-------------|---------------|---------------|---------------|---------------|---------------|---------------|------|
| | | Uni-T03L | Bi-T03LC | Uni-T05L | Bi-T05LC | Uni-T08L | Bi-T08LC | Uni-T12L | Bi-T12LC | |
| Min. Breakdown Voltage @ 1 mA | V _{BR} | 4.0 | 4.0 | 6.0 | 6.0 | 8.5 | 8.5 | 13.3 | 13.3 | V |
| Working Peak Voltage | V _M | 3.3 | 3.3 | 5.0 | 5.0 | 8.0 | 8.0 | 12.0 | 12.0 | V |
| Maximum Clamping Voltage @ I _p = 1 A | V _F | 6.5 | 7.0 | 9.8 | 9.8 | 13.4 | 13.4 | 19.0 | 19.0 | V |
| Typical Clamping Voltage @ 8/20 μs @ I _{pp} | V _C | 20 V @ 24 A | 20 V @ 24 A | 18.3 V @ 15 A | 18.3 V @ 15 A | 18.3 V @ 15 A | 18.3 V @ 15 A | 28.6 V @ 11 A | 28.6 V @ 11 A | V |
| Maximum Leakage Current @ V _{WM} | I _D | 5 | 5 | 5 | 5 | 2 | 2 | 1 | 1 | μA |
| Typical Capacitance @ 0 V, 1 MHz | C _P | 1.0 | | | | | | | | pF |

Notes:

1. Part numbers with suffix "C" indicate bidirectional device, i.e. CDSOD323-T05LC.
2. For bidirectional devices only, the electrical specifications apply in both directions.
3. Unidirectional only: Positive potential is applied from pin 1 to 2.

BOURNS®

Asia-Pacific: Tel: +886-2 2562-4117 • Fax: +886-2 2562-4116

Europe: Tel: +41-41 768 5555 • Fax: +41-41 768 5510

The Americas: Tel: +1-951 781-5500 • Fax: +1-951 781-5700

www.bourns.com

*No lead detected in standard tests of homogeneous materials.

**RoHS Directive 2002/95/EC Jan 27, 2003 including Annex.

Specifications are subject to change without notice.

Customers should verify actual device performance in their specific applications.

CDSOD323-TxxLC - TVS Diode Series

BOURNS®

Electrical & Thermal Characteristics (@ $T_A = 25^\circ\text{C}$ Unless Otherwise Noted)

| Parameter | Symbol | CDSOD323- | | | | | | Unit |
|---|----------|---------------|---------------|--------------|--------------|--------------|--------------|---------------|
| | | Uni-T15L | Bi-T15LC | Uni-T18L | Bi-T18LC | Uni-T24L | Bi-T24LC | |
| Min. Breakdown Voltage @ 1 mA | V_{BR} | 16.7 | 16.7 | 20.0 | 20.0 | 26.7 | 26.7 | V |
| Working Peak Voltage | V_M | 15.0 | 15.0 | 18.0 | 18.0 | 24.0 | 24.0 | V |
| Maximum Clamping Voltage @ $I_P = 1\text{ A}$ | V_F | 24.0 | 24.0 | 29.0 | 29.0 | 43.0 | 43.0 | V |
| Typical Clamping Voltage @ $8/20\ \mu\text{s}$ @ I_{PP} | V_C | 31.8 V @ 10 A | 31.8 V @ 10 A | 45.0 V @ 8 A | 45.0 V @ 8 A | 56.0 V @ 6 A | 56.0 V @ 6 A | V |
| Maximum Leakage Current @ V_{WM} | I_D | 1 | | | | | | μA |
| Typical Capacitance @ 0 V, 1 MHz | C_J | 1.0 | | | | | | pF |

Notes:

1. Part numbers with suffix "C" indicate bidirectional device, i.e. CDSOD323-T05LC.
2. For bidirectional devices only, the electrical specifications apply in both directions.
3. Unidirectional only: Positive potential is applied from pin 1 to 2.

Performance Graphs

Peak Pulse Power vs. Pulse Time

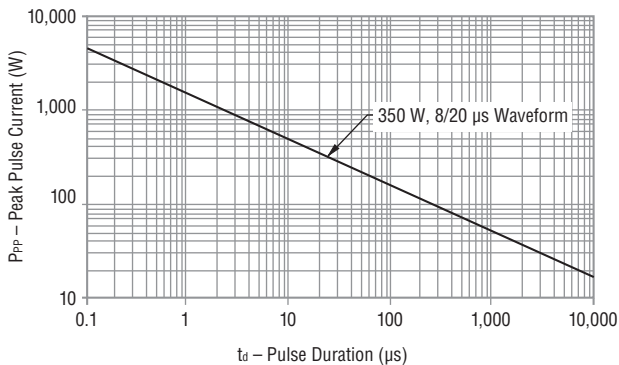

Pulse Waveform

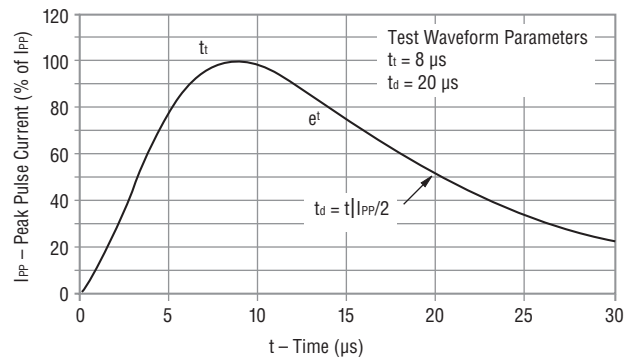

Block Diagram

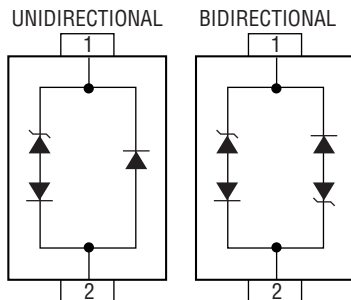

How to Order

Common Code _____ **CD SOD323 - T 05 LC**

Chip Diode _____

Package _____

- SOD323 = SOD-323 Package

Model _____

T = Transient Voltage Suppressor

Working Peak Reverse Voltage _____

05 = 5 V_{RWM} (Volts)

Suffix _____

L = Ultralow Capacitance Unidirectional Diode

LC = Ultralow Capacitance Bidirectional Diode

CDSOD323-TxxLC - TVS Diode Series

BOURNS®

Product Dimensions

This is a molded JEDEC SOD-323 package with lead free 100 % Sn plating on the terminations. It weighs approximately 30 mg and has a flammability rating of UL 94V-0.

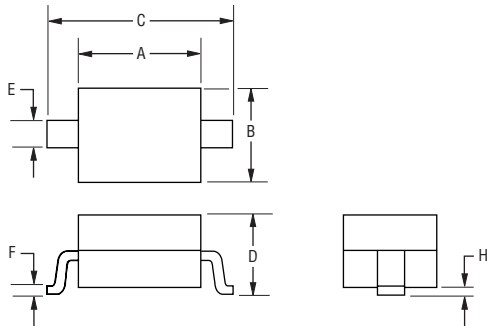

| Dimensions | |
|------------|---------------------------------------|
| A | $\frac{1.60 - 1.90}{(0.063 - 0.075)}$ |
| B | $\frac{1.15 - 1.45}{(0.045 - 0.057)}$ |
| C | $\frac{2.39 - 2.70}{(0.094 - 0.106)}$ |
| D | $\frac{0.92 - 1.10}{(0.036 - 0.043)}$ |
| E | $\frac{0.25 - 0.40}{(0.010 - 0.016)}$ |
| F | $\frac{0.10 - 0.20}{(0.004 - 0.008)}$ |
| H | $\frac{0.10}{(0.004)}$ MAX. |

DIMENSIONS: $\frac{\text{MM}}{\text{(INCHES)}}$

Recommended Footprint

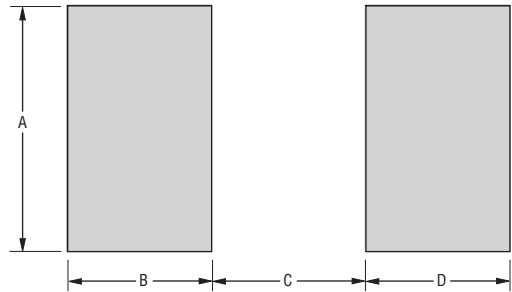

| Dimensions (Nominal) | |
|----------------------|------------------------|
| A | $\frac{0.80}{(0.031)}$ |
| B | $\frac{0.80}{(0.031)}$ |
| C | $\frac{1.40}{(0.055)}$ |
| D | $\frac{0.80}{(0.031)}$ |

DIMENSIONS: $\frac{\text{MM}}{\text{(INCHES)}}$

Typical Part Marking

Each device has device marking outlined below and the unidirectional devices have an additional Polarity Band indicating the cathode.

| | |
|----------------------|-----|
| CDSOD323-T03L | T3 |
| CDSOD323-T03LC | S3 |
| CDSOD323-T05L | T5 |
| CDSOD323-T05LC | S5 |
| CDSOD323-T08L | T8 |
| CDSOD323-T08LC | S8 |
| CDSOD323-T12L | T12 |
| CDSOD323-T12LC | S12 |
| CDSOD323-T15L | T15 |
| CDSOD323-T15LC | S15 |
| CDSOD323-T18L | T18 |
| CDSOD323-T18LC | S18 |
| CDSOD323-T24L | T24 |
| CDSOD323-T24LC | S24 |

CDSOD323-TxxLC - TVS Diode Series

BOURNS®

Packaging Information

The surface mount product is packaged in an 8 mm x 4 mm tape and reel format per EIA-481 standard.

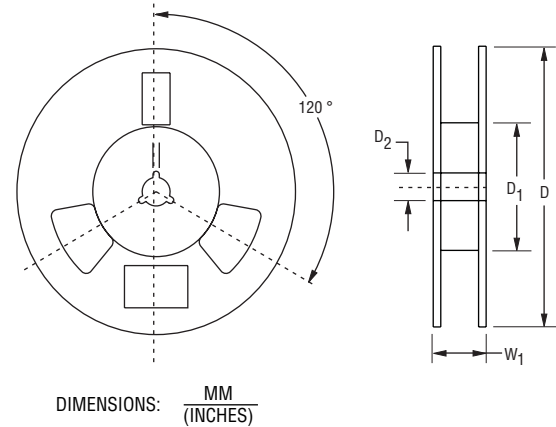
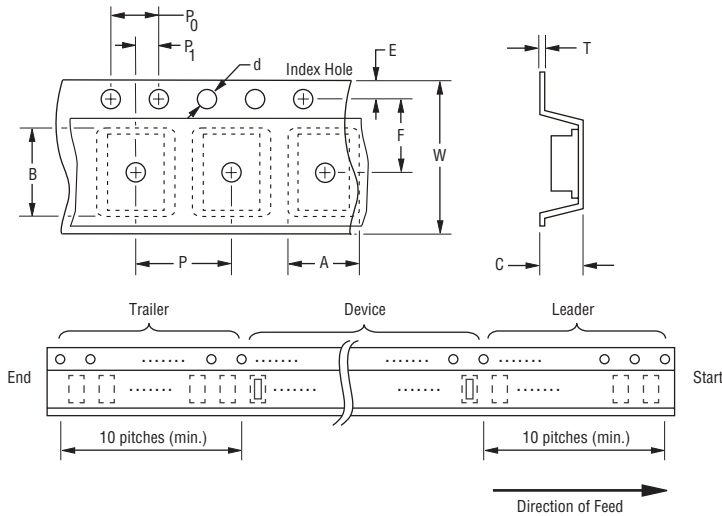

Devices are packed in accordance with EIA standard RS-481-A.

| Item | Symbol | SOD-323 |
|------------------------|----------------|---|
| Carrier Width | A | $\frac{1.55 \pm 0.10}{(0.061 \pm 0.004)}$ |
| Carrier Length | B | $\frac{2.90 \pm 0.10}{(0.114 \pm 0.004)}$ |
| Carrier Depth | C | $\frac{1.35 \pm 0.10}{(0.053 \pm 0.004)}$ |
| Sprocket Hole | d | $\frac{1.55 \pm 0.05}{(0.061 \pm 0.002)}$ |
| Reel Outside Diameter | D | $\frac{178}{(7.008)}$ |
| Reel Inner Diameter | D ₁ | $\frac{80.0}{(3.150)}$ Min. |
| Feed Hole Diameter | D ₂ | $\frac{13.0 \pm 0.20}{(0.512 \pm 0.008)}$ |
| Sprocket Hole Position | E | $\frac{1.75 \pm 0.10}{(0.069 \pm 0.004)}$ |
| Punch Hole Position | F | $\frac{3.50 \pm 0.05}{(0.138 \pm 0.002)}$ |
| Punch Hole Pitch | P | $\frac{4.00 \pm 0.10}{(0.157 \pm 0.004)}$ |
| Sprocket Hole Pitch | P ₀ | $\frac{4.00 \pm 0.10}{(0.157 \pm 0.004)}$ |
| Embossment Center | P ₁ | $\frac{2.00 \pm 0.05}{(0.079 \pm 0.002)}$ |
| Overall Tape Thickness | T | $\frac{0.20 \pm 0.10}{(0.008 \pm 0.004)}$ |
| Tape Width | W | $\frac{8.00 \pm 0.20}{(0.315 \pm 0.008)}$ |
| Reel Width | W ₁ | $\frac{13.5}{(0.531)}$ Max. |
| Quantity per Reel | -- | 3,000 |

REV. 09/11

Specifications are subject to change without notice. Customers should verify actual device performance in their specific applications.