

Circuit Protection Application Note

LVDS Applications with RTCA-DO160 High-Speed Lightning Transient Susceptibility



About The Protection

This application note details lightning surge and AC power fault protection for adaptive cable equalizer and serial cable driver LVDS devices. The lightning induced transient susceptibility tests defined in test standard RTCA-DO160 includes high-frequency (1 MHz and 10 MHz) requirements. The TBU™ device solution provides superior circuit protection for avionics DO-160 compliance. During this extensive evaluation the LVDS adaptive equalizer and the serial cable driver chipsets were fully protected from surge and power faults when protected by the Bourns® TBU device solution. Further results show that the low capacitance and superior bandwidth of the solution have minimal effect on the normal performance of the circuit.

Scope

As low voltage differential signaling (LVDS) communications lines begin interfacing to the outside environment, the external lines will be exposed to lightning surge and power cross. To protect LVDS transceivers (line drivers, equalizers) from these transients, an understanding of the stress caused during surges is needed. This document will describe:

Surge Protection

- Burst surge requirement used to test LVDS surge compliance
- Protection measurements with and without LVDS devices
- The stress to LVDS devices created by these surges
- Transient Blocking Unit (TBU) device protection solutions available to reduce stress on LVDS devices

Summary

The LVDS serial digital cable driver and adaptive equalizer chipsets were protected from electrical overstress due to lightning surge and power cross conditions.



Introduction

Low voltage differential signaling technology is useful for interface applications requiring high bandwidth. As communications networks increase in presence both inside and outside the home or office, LVDS signaling will travel on transmission line applications that may be exposed to electrical overstress due to high-speed lightning transient levels at 1 MHz and 10 MHz. The low voltage signaling level of LVDS may be exposed to 100 s to 1000 s of volts due to a lightning strike. A highly effective protection method is required that protects and maintains the wide bandwidth requirements of LVDS applications.

The Bourns protection solutions suitable for high-speed interface devices consist of gas discharge tubes (GDT) and transient blocking units. Incremental lightning susceptibility requirements are high-burst energy signals that go beyond standard lightning surge and/or power fault tests for GR-1089 CORE, IEC 61000-4-5, and ITU-T K.21.

The requirements may be one or more of the following:

- The 10 MHz burst energy requirement is a sinusoidal 1500 Vac at 60 A, which is as high as 60 kV/ μ s
- The 1 MHz burst energy is a sinusoidal 600 Vac at 24 A, which is as high as 24 kV/ μ s

The tests are specifically for avionics applications and consist of high-frequency and higher voltage than standard tests.



Background

Figure 1 shows Bourns’ standard protection schematic for LVDS devices. A similar TBU-based solution will protect against the lightning surge and power fault tests for GR-1089 CORE, IEC 61000-4-5, and ITU-T K.21. Contact Bourns for more details.

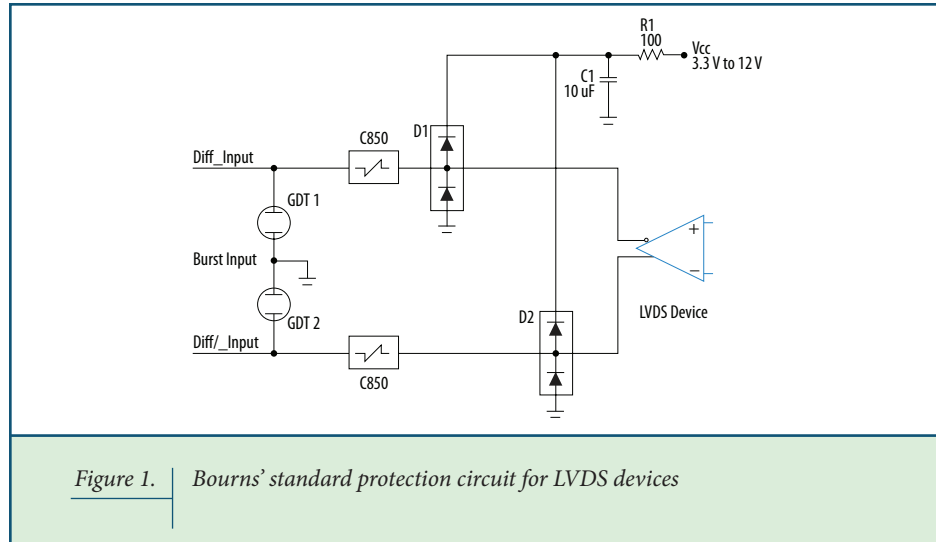

Figure 1. Bourns’ standard protection circuit for LVDS devices

Higher energy transients are found in the DO-160 standards for avionics applications. An example of a higher energy transient from the DO-160 specification is a high-frequency, high-energy burst signal. The burst energy requirements of DO-160 are referred to as lightning transient susceptibility. However, in this document, to distinguish the DO-160 lightning transient from a typical GR-1089 lightning transient, this document will refer to the high-frequency DO-160 requirements as “burst” or “burst risetime.” Passing the burst energy in the DO-160 standard requires additional circuitry from the basic protection circuit of figure 1 as significant ‘let-through’ energy can pass through the basic C850 configuration at these extremely high transient speeds.



TBU Protection Solution with LVDS Devices

The following section was performed with interface devices:

- Adaptive Equalizer
- Serial Digital Cable Driver

Adaptive Equalizer

Bourns' high-frequency burst protection circuit for the Adaptive Equalizer is illustrated in figure 2 and figure 3. Due to the high-energy of the burst input signal, two stages of protection are required which include a C850-180-WH and P40-240-WH TBU device.

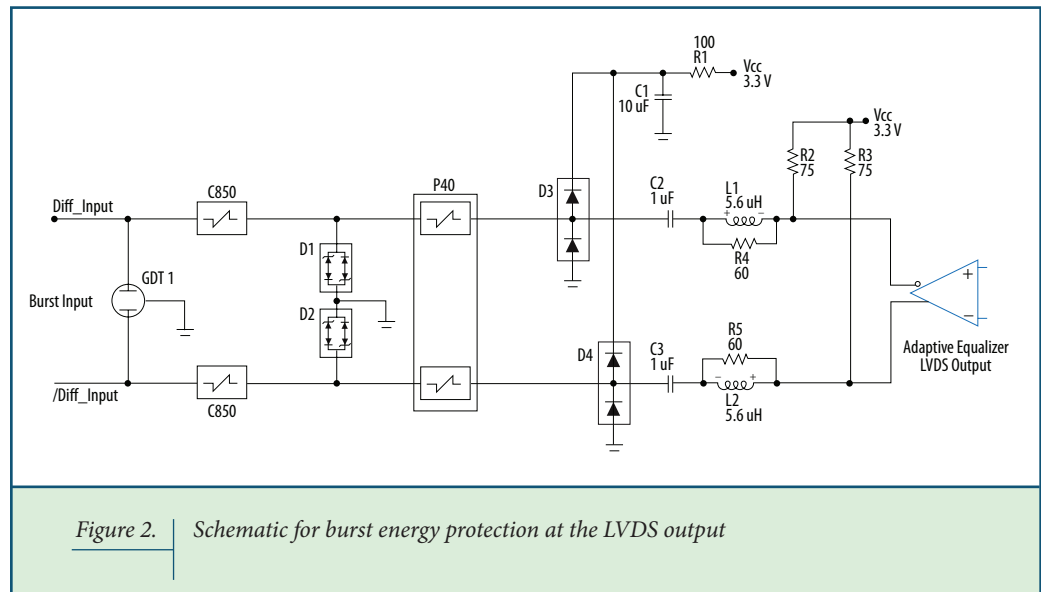

Figure 2. Schematic for burst energy protection at the LVDS output

The circuit works as follows. The protection circuit passes all normal LVDS signals while maintaining a high transmission line performance. Figure 2 shows the schematic to protect the output stage of the LVDS adaptive equalizer. A high burst signal has positive rising and negative falling voltage transitions. As the burst voltage increases beyond normal LVDS levels, diodes D3 and D4 limit the voltage beyond the power supply rail thus protecting the equalizer output stage. D3 and D4, generic, low power, dual high-speed diodes are low cost, small devices. The P40 triggers once current flows into the dual diode device. As the voltage increases, D1 and D2, Bourns® CDSOD323-T12C device, clamps the input energy. The C850 TBU device triggers and protects as the input voltage increases. The GDT activates and shunts the input energy to ground. The circuit is protected. LVDS equalizer operation is verified with a signal generator and an oscilloscope. The equalizer is operational after the transient conditions.



Adaptive Equalizer (continued)

Figure 3 shows the same protection circuit for the input stage of the LVDS equalizer.

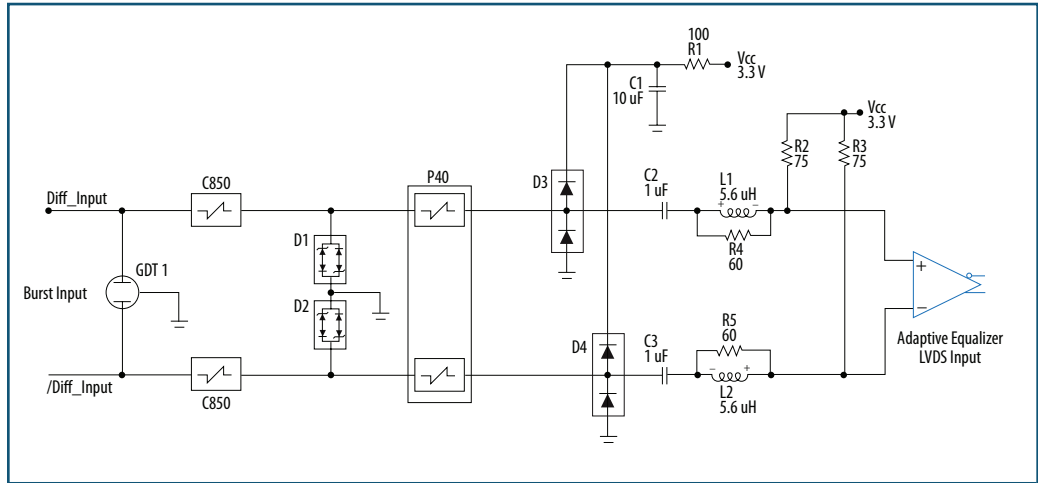

Figure 3. Schematic for burst energy protection at the LVDS input

Serial Digital Cable Driver

Bourns' high-frequency burst protection circuit for the LVDS driver is shown in figure 4. The circuit works in the same manner as the schematic in figure 2 and figure 3. The serial cable driver is protected. LVDS equalizer operation is verified with a signal generator and an oscilloscope. The equalizer is operational after the transient conditions.

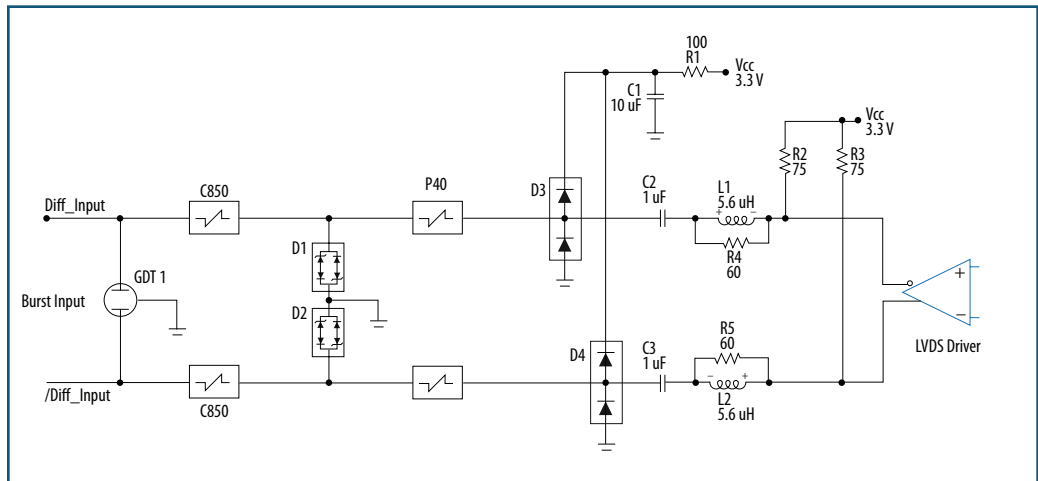
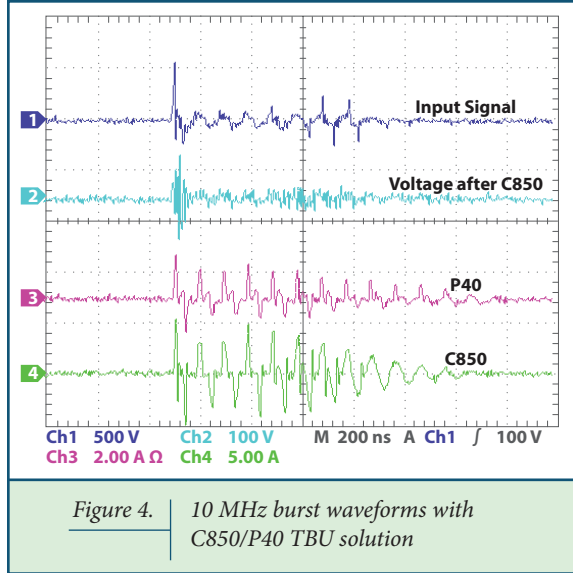

Figure 4. Schematic for burst energy protection



Bench Measurement

Figure 5 shows the 10 MHz oscilloscope waveforms using a DO-160 burst generator. The 10 μ F capacitor absorbs the surge energy into the power supply and the 100 ohm resistor limits the current into the rail.



Channel 1: 10 MHz burst generator voltage surge
 Channel 2: Clamp diodes between C850 and input to P40
 Channel 3: Let-through current of P40
 Channel 4: Let-through current of C850

Figure 4. 10 MHz burst waveforms with C850/P40 TBU solution

Summary

LVDS transient protection is a challenge for the high-voltage, burst transient levels required for DO-160 compliance. LVDS transient protection against high-frequency, high-current energy is achieved by using a TBU device solution. The table below summarizes the transient test results with the LVDS adaptive equalizer and serial driver chipsets. A passing result means that no damage or stress occurred to the LVDS devices or to the protection circuits. The Bourns® TBU device solution protects the LVDS drivers from the high-energy transient conditions.

Transient Protection Results

Chipset	1500 V, 10 MHz Burst, 60 A	600 V, 1 MHz Burst, 24 A
Adaptive Equalizer	Pass	Pass
Serial Driver	Pass	Pass

For more information on TBU devices and other circuit protection products from Bourns, please visit

www.bourns.com

COPYRIGHT © 2009 • BOURNS, INC. 04/09 e/FU0930
 "TBU" is a trademark of Bourns, Inc.
 "Bourns" is a registered trademark of Bourns, Inc. in the U.S. and other countries.