

Features

- Non-contacting sensor
- Operating temperature: -40 °C to +85 °C

Commercial Vehicle Non-Contacting Chassis Level Sensor - Type R11700

General Function

Bourns® Type R11700 Non-contacting Chassis Level Sensor is used to measure the vehicle height in commercial vehicles or busses. The sensor sends a continuous signal which is an indicator for the level of the chassis. It is mounted at the frame of the commercial vehicle or bus. The sensor measurement is non-contacting and is based on magnetic field direction measurement. An outside lever is mounted at an axle and turns a magnet inside the sensor housing. The output signal of the sensor is proportional to the angle of the sensor axle.

General Specifications

Ambient Conditions Atmospheric air
 (comprised of water, salt, oil, technical grease, etc.)
 Temperature Range -40 °C to 85 °C (optional 110 °C)
 Humidity 0 to 100 % RF
 Protection Class IP6K9 / IP6K8
 DIN 40 050 sheet 9 (connector connected)
 Electrical Connector DIN 72585 (see diagram)
 Screw Down Torque 15 Nm max. (M8)
 Lifetime >12 years or
 min. 1 million full strokes ($\pm 80^\circ$);
 min. 300 million short strokes ($\pm 1^\circ$)
 Service Requirements None
 Weight ca. 180 g

Functional Specifications

Sensor Mechanical Angular Range > 360 ° (no end stops)
 Typical Operating Range $2^\circ \pm 80^\circ$
 (right side and left side mounting possible)
 Linearity Error < 1 °
 Resolution < 0.1 °
 Operational Torque 1 Nm max.
 Axial Load 20 N max.
 Axial Shock 100 N (14 ms) max.
 Radial Load 20 N max.
 Radial Shock 100 N (14 ms) max.
 Supply Voltage 5.0 ± 0.5 VDC
 Output Options Analog (12 bit, ratiometric to supply,
 pull-up/pull-down possible) PWM
 Output Update Rate > 1 kHz
 Current Consumption < 18 mA
 Overvoltage Protection 20 V
 Reverse Voltage Protection -10 V
 ESD Protection ± 15 kV (air discharge);
 ± 8 kV (direct discharge)

Electrical Connector

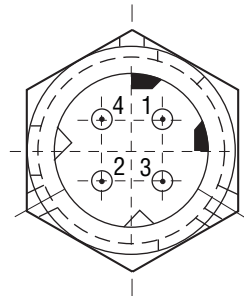

- Pin 1 = Supply
- Pin 2 = GND
- Pin 3 = Not Connected
- Pin 4 = Signal

Typical CLS Output

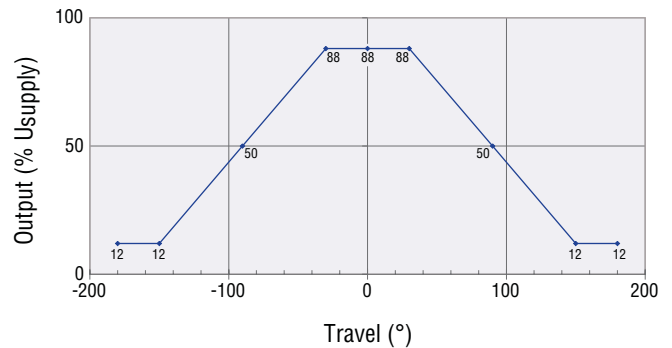

Design and Mechanical Interface

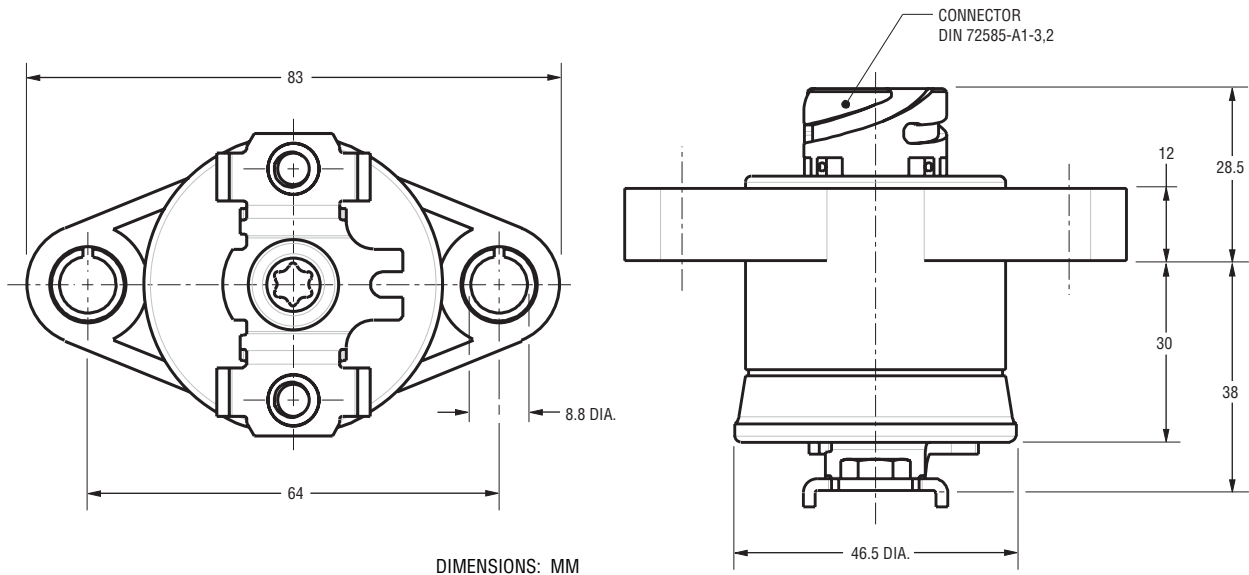

BOURNS®
Automotive Division

Europe:

Bourns Sensors GmbH
Robert-Bosch-Str. 14
D-82054 Sauerlach
Phone: +49 (0) 8104 646-0

The Americas:

Bourns, Inc.
1660 N. Opdyke Road, Ste. 200
Auburn Hills, MI 48326-2655 USA
Phone: +1 248 926-4088

Asia:

Bourns, Inc.
10F, No. 146, Sung Jiang Road
Taipei, Taiwan, 104 PRC
Phone: +886 2 2562-4117

www.bourns.com

automotive@bourns.com