

Application Note

Integrating Bourns® Resistive Products to Control Current and Protect LED Lighting

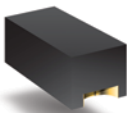

SMAJxxx



CD1005-B0520

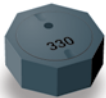

SRU1048



CRA2512



PWR263S



MF-MSMF

LED lighting has grown rapidly in popularity over the past several years, and there is no sign that this trend will change. Whether for refrigeration, industrial, automotive, residential, or consumer electronics, there are several points many LED lighting circuits have in common. Guidelines for circuit design and circuit protection must be followed to realize reliable performance and integration in cost-effective systems. The power supply, referred to as the LED driver, must remain within the safe operating current range of the LED. This application note examines LED driver circuit design in relation to overtemperature, surge, and ESD threats. It will introduce several resistive components from Bourns that are designed to address each threat. The application note will also provide a comprehensive LED lighting solution that uses these components.

Controlling the Current

Linear and switching current supplies are two popular types of LED drivers. When the supply voltage is slightly greater than the load voltage, a linear current supply may be incorporated in the design. In the case of a linear supply, current is limited by a resistor. A switching supply, available for a range of voltages, is more efficient than a linear supply and generates less heat in the circuit.

Current sense resistors provide the feedback necessary for the current regulation controller to monitor and limit the current fed to the LED diode string. An inductor is generally used in the LED driver interface as well. It is important to choose an inductor with low DC resistance to ensure low energy consumption. Generally, LED applications require a shielded inductor.

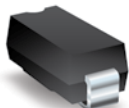

SMAJxxx

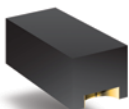

CD1005-B0520

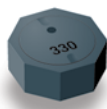

SRU1048



CRA2512



PWR263S



MF-MSMF

Threats to LED Lighting Reliability

Overtemperature

Unlike filament and plasma-based lighting (traditional light bulbs and neon), LED lighting is very sensitive to heat. The PN junction cannot be allowed to reach temperatures greater than +85 °C to ensure high reliability and normal operating life. Polymer Positive Temperature Coefficient (PPTC) devices limit current and react to increases in temperature to provide overtemperature protection for the LED.

Surge and ESD

In many product package designs, the LED device package is exposed to external environmental conditions and, thus, is susceptible to external ESD transients that can damage the LEDs or downstream circuitry. To help avoid damage, the use of ESD protection devices across the LED is required to meet IEC 61000-4-2 Level 4 ESD standard requirements. Protection to IEC 61000-4-4 EFT and IEC 61000-4-5 surge standards is advisable as well.

LED Protection Solutions from Bourns

Bourns offers components to meet each of the circuit design and circuit protection needs that were introduced. Figure 1 illustrates a comprehensive solution for an LED lighting application with a switching current supply as the LED driver. Based on the requirements of an individual application, the component values chosen from each product series may vary. Beginning with the power supply and LED driver, an inductor must be selected in addition to resistors for current limiting and current sensing.

Bourns® CRA2512 Series are current sense resistors with a high power density (3 W) and low TCR (75 PPM) in a standard 2512 chip size. The surface temperature of this special alloy resistor remains low, typically reaching 48 °C under a load of 1 W. Bourns® CRM2512 is a thick film pulse resistor for current sensing and inrush current limiting. Also in a 2512 package, Bourns® CRM2512 has a low TCR (100 PPM) and reaches 70 °C under a load of 2 W.

LED Protection Solutions from Bourns (Continued)

High current handling and low DC resistance in a compact form factor are available in Bourns® SRU1048 Series shielded inductor. This shielded SMD power inductor has a unit height up to 4.8 mm and rated current up to 7.8 A. Depending on the requirements of the circuit, a semi-shielded Bourns® SRN inductor may be substituted. The semi-shielded inductor gives designers a compromise solution between the superior performance of a shielded inductor and the cost-effectiveness of a non-shielded inductor. Along with the inductor, a Bourns® CD1005-B0520 Schottky barrier diode protects the circuit with its 0.5 A forward current and repetitive peak reverse voltage of 30 V.

Overtemperature protection is provided by a Bourns® MF-MSMF Series Multifuse® PTC. When current or temperature beyond a safe limit is detected, this polymer PTC creates an effective open circuit by changing from a low resistance state to a high resistance state within 0.2 seconds. Bourns® MS-MSMF075 is rated to 13.2 V and 100 A.

In addition, ESD, EFT, and surge protection are included in the recommended LED lighting solution. Bourns® Model SMAJ Series transient voltage suppressor diode provides voltage signal clamping and protection against ESD, EFT and surge transients applied within the circuitry. Both the unidirectional and bidirectional options are used in this protection solution for LED lighting applications. Bourns® SMAJ Series meets the following industry test standards: IEC 61000-4-2 ESD Level 4, IEC 61000-4-4 EFT, and IEC 61000-4-5 Surge. The Bourns® diode is RoHS* compliant and is offered in a surface mount SMA package with a standoff voltage from 5 V to 179 V and can dissipate up to 400 W. Bourns® SMAJ Series is available in a compact DO-214AC package, making it ideal for portable electronics, embedded computing, communications, and video equipment.



SMAJxxx

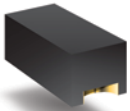

CD1005-B0520

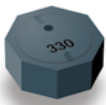

SRU1048



CRA2512



PWR263S



MF-MSMF

LED Protection Solutions from Bourns (Continued)

Figure 1 provides an example of an LED protection circuit, and many other solutions are available depending on the application. If the LED driver were a linear supply, then Bourns® PWR263S-20 Series would be ideal to limit the current, especially in high luminosity LEDs with high current consumption. These SMD resistors in D²PAK casings have very low inductance and high power ratings. Bourns® PWR263S-20 Series resistors do not exhibit high surface temperatures and thus meet the temperature requirements for many designs.

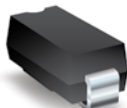

SMAJxxx

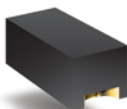

CD1005-B0520

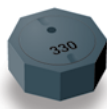

SRU1048



CRA2512



PWR263S



MF-MSMF

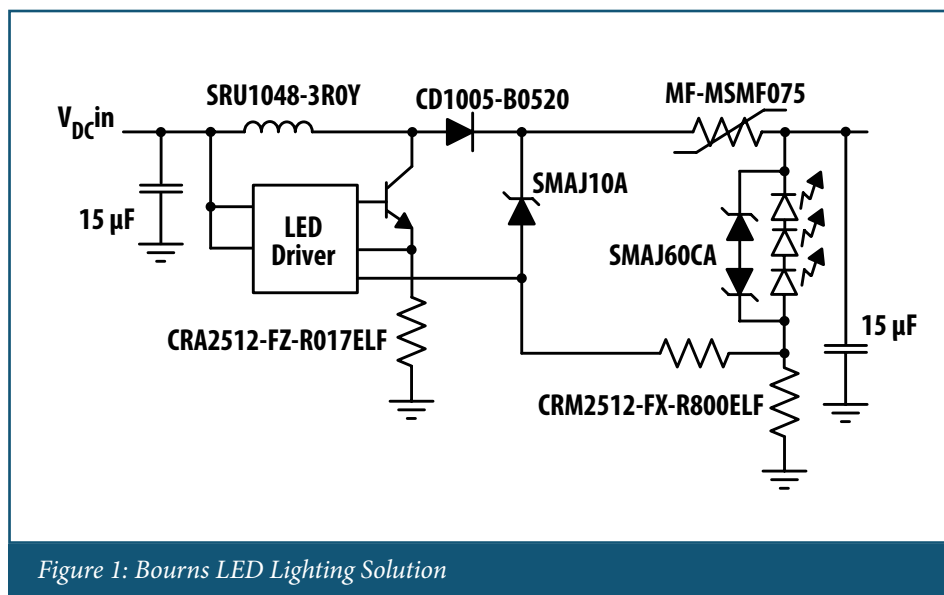
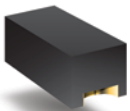

Figure 1: Bourns LED Lighting Solution

Integrating Bourns® Resistive Products to Control Current and Protect LED Lighting



SMAJxxx



CD1005-B0520

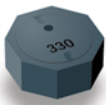

SRU1048



CRA2512



PWR263S



MF-MSMF

Taking Advantage of Bourns Technology Benefits

Bourns has been a leader in circuit protection for several decades. The company is committed to continued innovation in circuit protection technology and superior customer service. Bourns® resistive components and circuit protection solutions are available through an extensive network of manufacturer's representatives and distributors.

For more information on surge and ESD protection and other products from Bourns, please visit

www.bourns.com

COPYRIGHT© 2012 • BOURNS, INC. • 01/12 • e/CPK1173
"Multifuse" is a registered trademark of Bourns, Inc.
"Bourns" is a registered trademark of Bourns, Inc. in the U.S. and other countries.