

Features

- Plain or knurled shaft option
- 10 % TR tolerance
- Conductive polymer element
- Very low noise
- Single-turn
- 250K and 500K resistances



Model 82 Vintage Premium Guitar Potentiometer

Initial Electrical Characteristics¹

Standard Resistance Value	250K and 500K ohms
Total Resistance Tolerance	10 %
Independent Linearity	±5 %
Absolute Minimum Resistance	2 ohms maximum
Effective Electrical Angle	225 ° ± 5 °
Contact Resistance Variation	±1 %
Dielectric Withstanding Voltage (MIL-STD-202, Method 301)	
Sea Level	1,500 VAC minimum
70,000 Feet	500 VAC minimum
Insulation Resistance (500 VDC)	1,000 megohms minimum
Power Rating (Voltage Limited By Power Dissipation or 350 VAC, Whichever Is Less)	
+70 °C	0.25 watt
+125 °C	0 watt
Theoretical Resolution	Essentially infinite

Environmental Characteristics¹

Operating Temperature Range	-40 °C to +125 °C
Storage Temperature Range	-55 °C to +125 °C
Temperature Coefficient Over Storage Temperature Range	±1,000 ppm/°C
Vibration	15 G
Total Resistance Shift	±2 % maximum
Voltage Ratio Shift	±5 % maximum
Shock	30 G
Total Resistance Shift	±2 % maximum
Voltage Ratio Shift	±5 % maximum
Load Life	1,000 hours
Total Resistance Shift	±10 % maximum
Rotational Life (No Load)	100,000 cycles
Total Resistance Shift	±20 % maximum
Contact Resistance Variation @ 50,000 cycles	±3 %
Moisture Resistance (MIL-STD-202, Method 103, Condition B)	
Total Resistance Shift	±20 % TRS maximum
Insulation Resistance (500 VDC)	100 megohms minimum
IP Rating	IP 40

Mechanical Characteristics¹

Mechanical Angle	300 ° ± 5 °
Rotational Torque	0.7 oz-in (50 g-cm) typical
Weight21 grams
Terminals	J-hooks
Soldering Condition	Recommended hand soldering using Sn95/Ag5 no clean solder, 0.025 " wire diameter. Maximum temperature 399 °C (750 °F) for 3 seconds. No wash process to be used with no clean flux.
Marking	Manufacturer's trademark, date code, resistance, manufacturer's part number
Hardware	One lockwasher, one mounting nut, and one solder lug washer is shipped with each potentiometer

¹ AT ROOM AMBIENT: +25 °C NOMINAL AND 50 % RELATIVE HUMIDITY NOMINAL, EXCEPT AS NOTED.

Audio Taper Plot

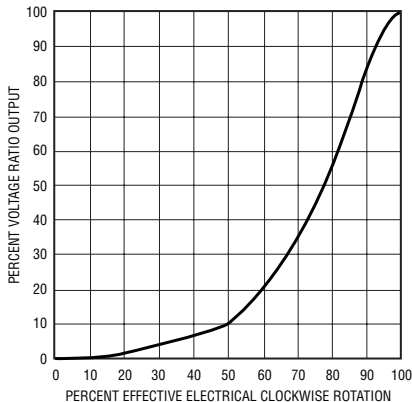

Selection Guide

Part Number	Taper/Shaft	Resistance Value (Ω)
82A1D-A24-BA0/186L	Audio/Plain	500K
82A1D-A24-BA0/187L	Audio/Plain	250K
82A1D-Z28-BA0/254L	Audio/Knurled	500K
82A1D-Z28-BA0/255L	Audio/Knurled	250K
82Z1D-Z33-BA0/753L	Audio/Knurled (Long Bushing)	250K
82Z1D-Z33-BA0/754L	Audio/Knurled (Long Bushing)	500K

Schematic

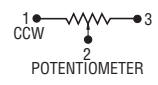

*RoHS Directive 2002/95/EC Jan 27 2003 including Annex Specifications are subject to change without notice. Customers should verify actual device performance in their specific applications.

Additional Features

- Standard audio taper
- Long rotational life
- RoHS compliant*

Applications

- Electric guitars
- Bass guitars

Model 82 Vintage Premium Guitar Potentiometer

BOURNS®

Product Dimensions

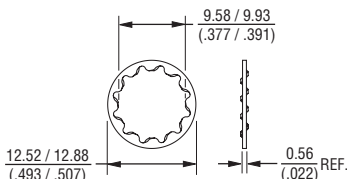
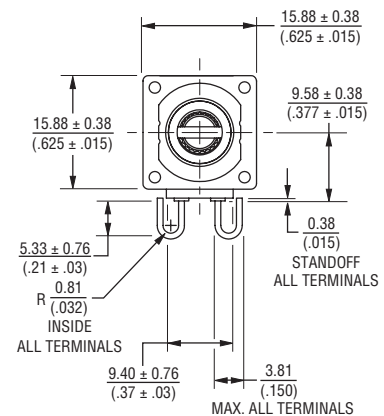
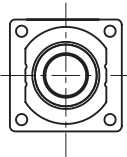
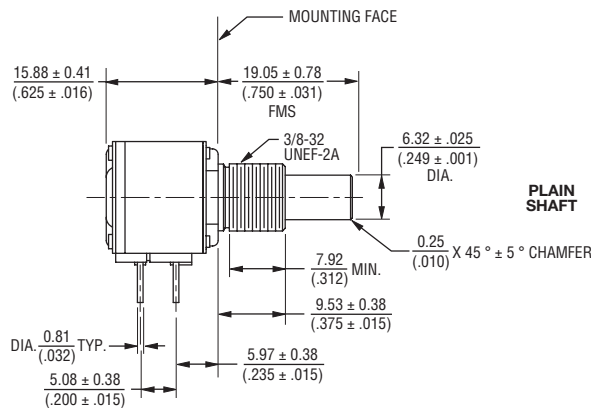
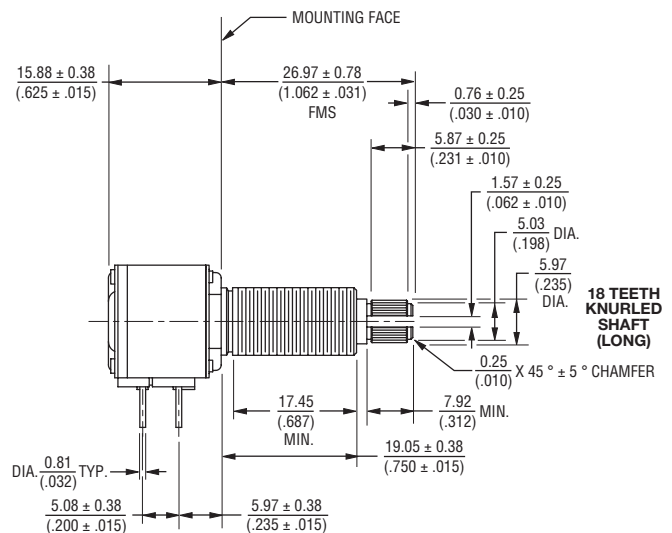
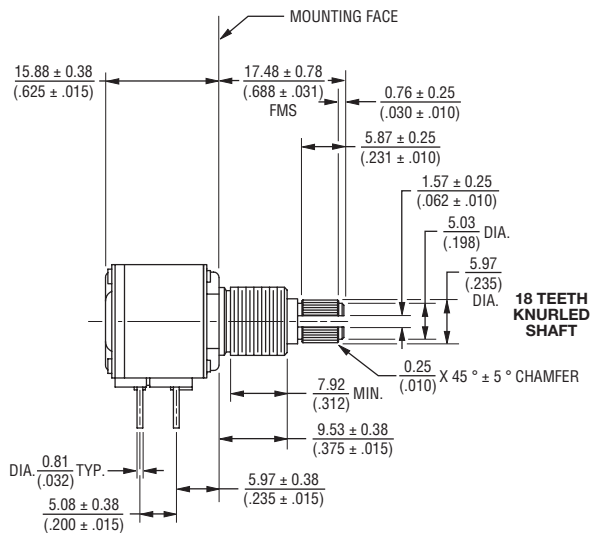

LOCKWASHER

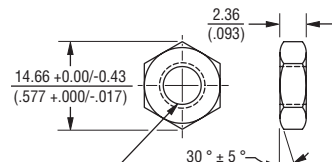

HEX NUT

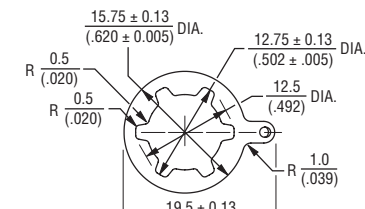

SOLDER LUG WASHER

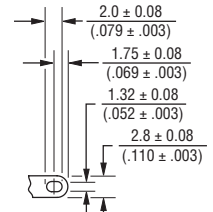

DIMENSIONS: $\frac{\text{MM}}{\text{(INCHES)}}$

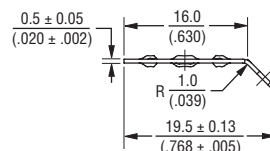

REV. 06/10

Specifications are subject to change without notice. Customers should verify actual device performance in their specific applications.