

## Features

- Rechargeable battery-pack applications
- Precious metal contacts
- Tape & reel available
- RoHS compliant\* - see [processing information](#) on RoHS compliant surface mount components
- For applications/processing guidelines, [click here](#)

# 70AD/Female - Modular Contact

## Materials & Finishes

Insulator Glass reinforced thermoplastic, UL 94V-0 rated, black  
 Contact ..... Copper alloy Finish  
 Underplating..... 30 μ" to 60 μ" Ni  
 Contact Area ..... 30 μ" min. Au over Ni  
 Termination..... Tin alloy (meets MIL-STD-202, method 208)

## Operating Characteristics

**Electrical**  
 Current Rating..... DC 3 A/contact  
 Voltage Rating..... DC 30 V  
 Contact Resistance..... 25 mΩ max.  
 Dielectric Voltage ..... AC 500 V  
 Insulating Resistance..... 500 MΩ min.  
 Operating Temperature ..... -55 °C to 125 °C

**Mechanical**  
 Durability ..... 5,000 cycles

## How to Order

**70AD J - 3 - F L 0 G**

Model \_\_\_\_\_  
 Terminal Style \_\_\_\_\_  
 J = SMT  
 H = Through-hole  
 Number of Contacts \_\_\_\_\_  
 2 through 6  
 Gender \_\_\_\_\_  
 F = Female  
 Height \_\_\_\_\_  
 L = Low Profile  
 Options \_\_\_\_\_  
 0 = Standard  
 1 = Locator Pins (J style only)  
 Packaging Option \_\_\_\_\_  
 — = Tube (240/N pcs. or 240 contacts per tube)  
 G = Embossed Tape (500 pcs. per reel)

Number of Contacts	Dim. A	Dim. B	Dim. C
2	9.0 (.354)	4.0 (.157)	7.0 (.276)
3	13.0 (.512)	8.0 (.315)	11.0 (.433)
4	17.0 (.669)	12.0 (.472)	15.0 (.591)
5	21.0 (.827)	16.0 (.630)	19.0 (.748)
6	25.0 (.984)	20.0 (.787)	23.0 (.906)

## Product Dimensions

70ADJ

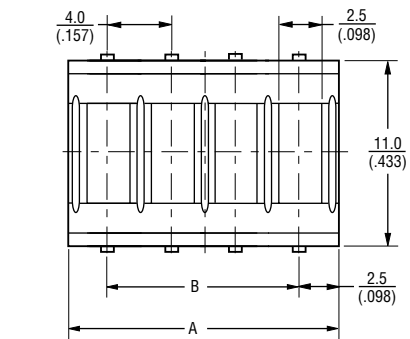

70ADH

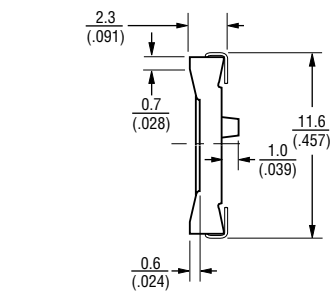
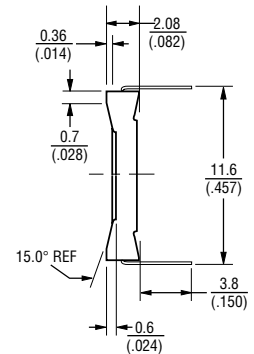
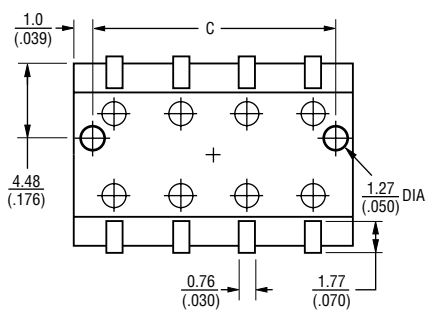
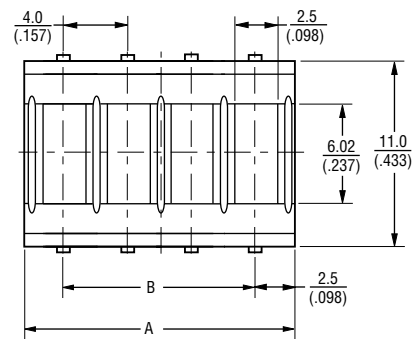

70ADH RECOMMENDED PWB MOUNTING PATTERN

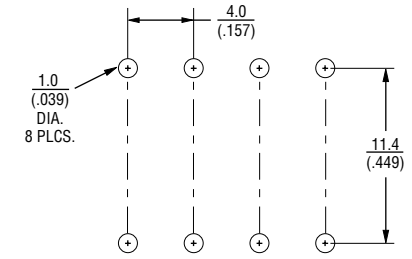

70ADJ RECOMMENDED PWB MOUNTING PATTERN

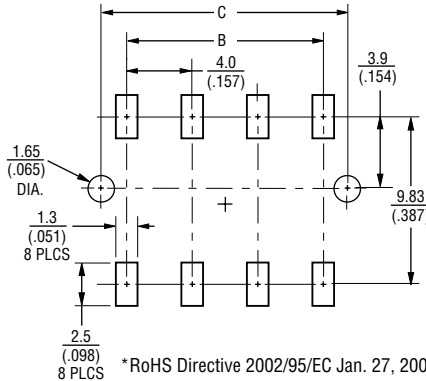

TOLERANCES: 0.3 (.012) UNLESS OTHERWISE NOTED  
 DIMENSIONS: MM (INCHES)

\*RoHS Directive 2002/95/EC Jan. 27, 2003 including annex and RoHS Recast 2011/65/EU June 8, 2011. Specifications are subject to change without notice. Customers should verify actual device performance in their specific applications.

# 70AD/Female - Modular Contact

**BOURNS®**

## Packaging Specifications

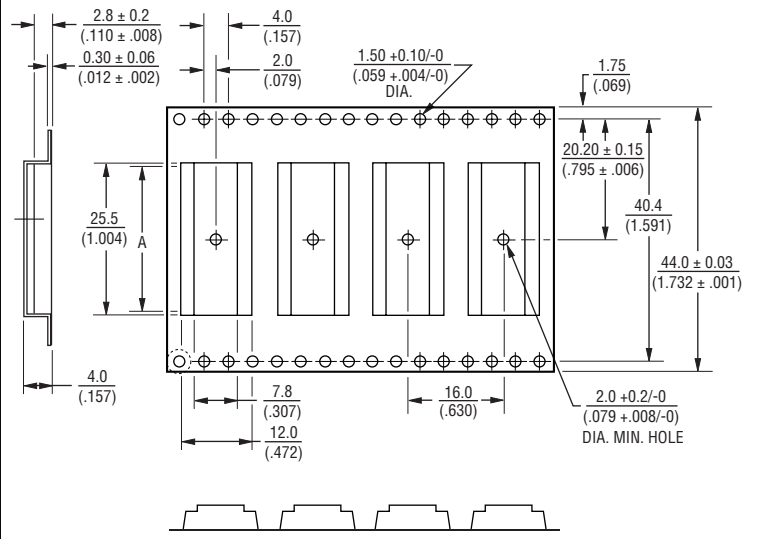
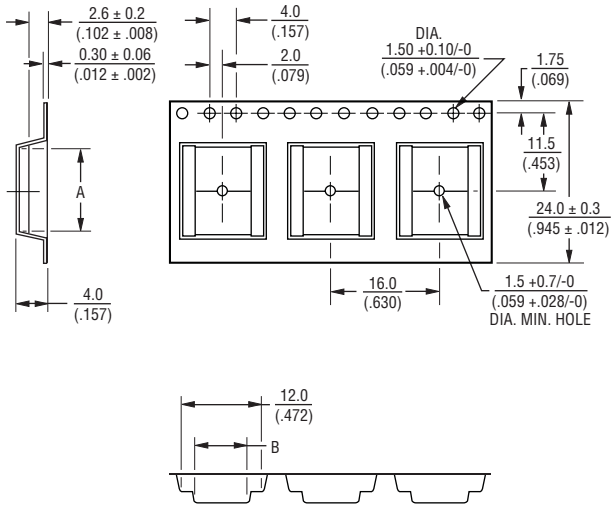

No. of Contacts	Dimension A	Dimension B
2	$\frac{9.5}{(.374)}$	$\frac{8.3 \pm 0.2}{(.327 \pm .008)}$
3	$\frac{13.5}{(.531)}$	$\frac{8.3 \pm 0.2}{(.327 \pm .008)}$
4	$\frac{17.5}{(.689)}$	$\frac{7.8}{(.307)}$

No. of Contacts	Dimension A
5	$\frac{19.5}{(.768)}$
6	$\frac{25.5}{(1.004)}$

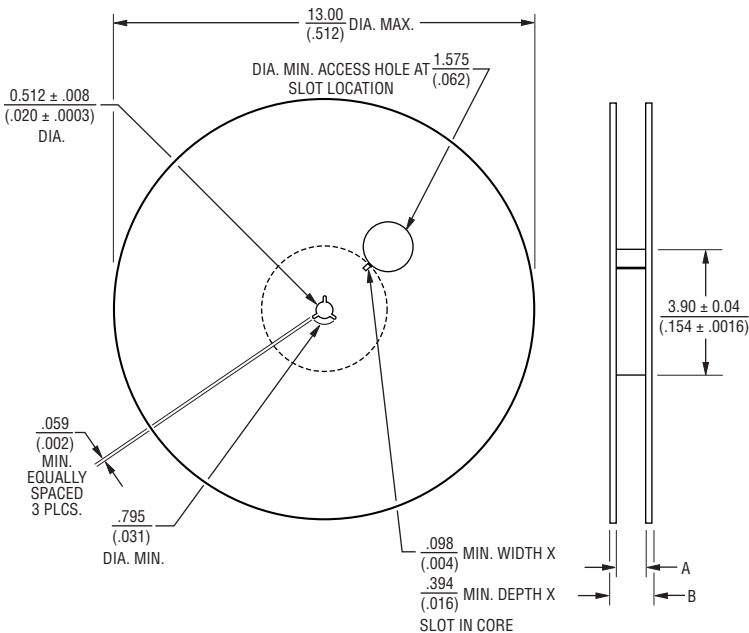

No. of Contacts	Dimension A	Dimension B
2	$\frac{.961}{(.038)}$	$\frac{1.197}{(.047)}$
3	$\frac{.961}{(.038)}$	$\frac{1.197}{(.047)}$
4	$\frac{.961}{(.038)}$	$\frac{1.197}{(.047)}$
5	$\frac{1.765}{(.069)}$	$\frac{1.98}{(.078)}$
6	$\frac{1.765}{(.069)}$	$\frac{1.98}{(.078)}$

DIMENSIONS:  $\frac{\text{MM}}{\text{(INCHES)}}$

REV. 11/11

Specifications are subject to change without notice. Customers should verify actual device performance in their specific applications.