



BOURNS®

Features

- Multi-Stage Protection (MSP®)
- Balanced TRIGARD® GDT
- Self-resetting sneak current protection with Bourns® TBU® Electronic Current Limiter (ECL)
- Overcurrent and overvoltage protection
- Fast response to transients
- High current handling
- Switch-Grade Fail-Short
-  UL LISTED UL Listed per UL 497 (File: E53117)

2470 Series 5-Pin TBU® Surge Protector

Bourns® 2470 Series 5-Pin TBU® Protector is a new generation of telecommunications protector designed for protection of sensitive high-speed network data circuits. Bourns® 2470 Series 5-Pin TBU® Protector integrates four advanced technologies: Our proprietary advanced balanced TRIGARD® GDT, precision matched Metal Oxide Varistors (MOVs), a patented Switch-Grade Fail-Short mechanism, and our patented Transient Blocking Unit (TBU®) device that protects the circuit by rapidly switching to a blocking state. These technologies are combined to provide robust overvoltage and fast, resettable sneak-current protection with extremely low surge let-through. Additionally, the 2470 Series has very low loss characteristics making it the ultimate choice for protection of sensitive, high speed communication lines.

Characteristics

Test Methods per IEEE C62.31, UL 497, CSA C22.2, Telcordia GR 1361 and applicable sections of Telcordia GR 974.

DC Breakdown ¹	300-400 V
AC Breakdown ¹	300-400 V
Impulse Breakdown.....	60 Hz..... 600 V
	100 V/μs..... 600 V
	1000 V/μs..... 650 V
Insulation Resistance.....	100 Vdc..... > 1 GΩ
Insertion Loss.....	100 MHz..... < 1 dB over frequency range ²
Return Loss.....	100 MHz..... < 10 dB over frequency range ²
Capacitance Line to Line.....	1 MHz..... 12 pF typical
Capacitance Line to Ground.....	1 MHz..... 23 pF typical
Line Resistance (Line In - Line Out).....	12 ohms typical
V _{reset}	< 14 V typical ³
Impulse Reset ⁴	52 V, 260 mA..... < 10 ms ⁵
	135 V, 200 mA..... < 10 ms ⁵
	150 V, 200 mA..... < 150 ms ⁵
Impulse Life Characteristics.....	100 A, 10/1000 μs..... > 3000 operations ⁶
(Per Side, Simultaneously)	300 A, 10/1000 μs..... > 1000 operations ⁶
	500 A, 10/1000 μs..... > 1000 operations ⁷
	2,000 A, 10/250 μs..... > 100 operations ⁶
	5,000 A, 20/100 μs..... > 10 operations ⁶
	20,000 A, 8/20 μs..... > 10 operations ⁷
AC Life Characteristics.....	0.5 A rms continuous..... > 30 seconds
	1 A rms, 1 second, 600 ft. cable..... > 60 operations
	1 A rms, 1 second, 1 mile cable..... > 60 operations
	10 A rms, 1 second..... > 20 operations
	200 A rms, 11 cycles..... 1 operation ⁸
	120 A rms, 0.1 second..... 1 operation
Life Test Criteria	
Insulation Resistance Throughout the Life Test.....	100 megohms
Life Test Failures.....	0.0 %
Failures During Environmental Cycling w/surges.....	0.0 %
Fail-Short (Vented or Non-vented Gas Tube).....	> 30 Arms, simultaneously
Storage and Operating Temperature.....	-55 to +85 °C

Notes:

- ¹ Line to Line voltage is approximately 1.8 times the stated Line to Ground breakdown voltage.
- ² See insertion and return loss charts on page 2.
- ³ Designers should note that deliberate DC bias such as POTS (Plain Old Telephone Service), sealing current or remote powering can hold the TBU® device in a blocking state after a fault has passed. The TBU® sneak-current protector can be reset by momentarily disrupting the loop current or providing a low voltage condition on the line below the module's specified V_{reset} value. This can be accomplished, for example, with line monitoring or other line polling diagnostics in the system.
- ⁴ Network applied.
- ⁵ Surpasses Telcordia GR 974.
- ⁶ Exceeds Telcordia GR 1361.
- ⁷ RUS PE-80.
- ⁸ Protector may short to ground.

Applications

- Telecommunications
- Data communications
- High-speed network compatible, i.e. ADSL2+, VDSL2 and beyond

2470 Series 5-Pin TBU® Surge Protector **BOURNS®**

How to Order

2470 - 4 x(x) - x - xx - x(x)

Model Number Designator _____

Housing Color/Circuit Type _____

- 1 = Black/Standard
- 3 = Red/Special
- 6 = Blue/Standard
- 7 = Violet
- 9 = Orange/Standard Service (Non-Bridgelifter)
- 10 = Yellow/Standard

Pin Plating _____

- G = Gold-plated
- N = Tin-plated (GND pin is tin-plated on all models)

Protector Type _____

- Blank = Multi-Stage Protector (MSP®)
- BC = Balanced Capacitance MSP®*

Special Options _____

- S = Sealed Case
- ST = Sealed Case and Test Points
- T = Test Points

* For use on DSL systems that require balanced capacitance of ≤ 1 pF.

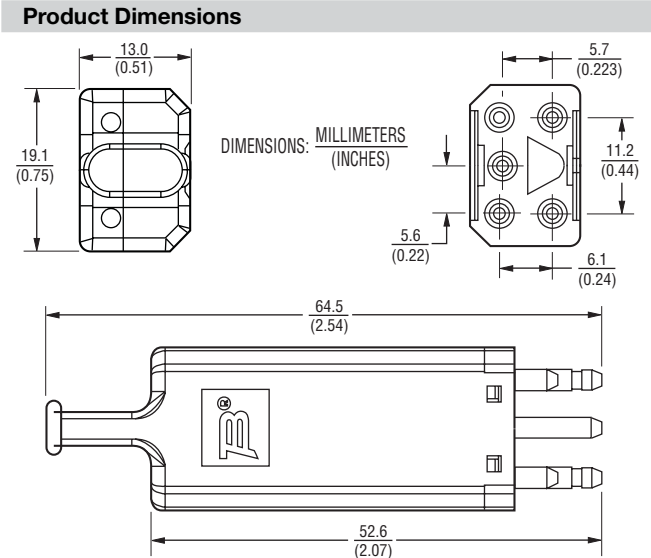

Loss Characteristics for 5-Pin Protector Groups with Current Limiting Devices

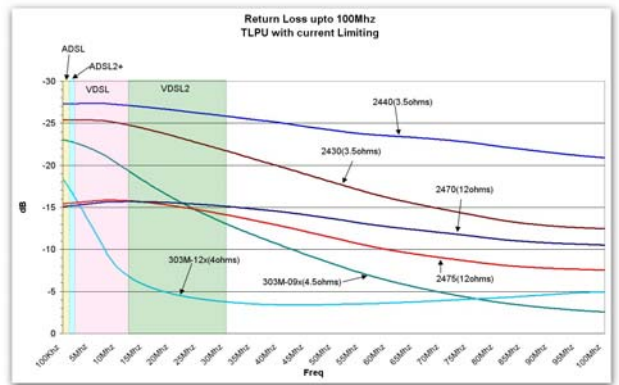
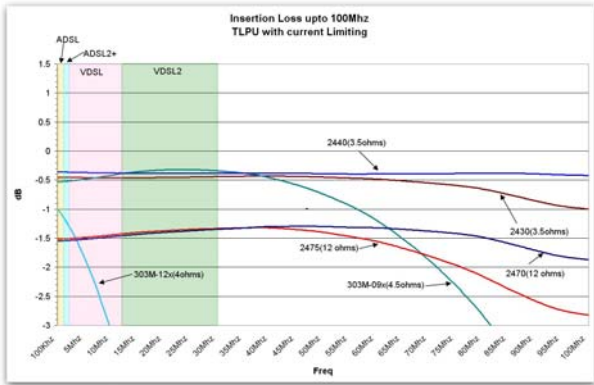

BOURNS®

Asia-Pacific: Tel: +886-2 2562-4117 • Fax: +886-2 2562-4116
Europe: Tel: +41-41 768 5555 • Fax: +41-41 768 5510
The Americas: Tel: +1-951 781-5500 • Fax: +1-951 781-5700
www.bourns.com

REV. B 04/11
 "BOURNS", "MSP and "TRIGARD" are registered trademarks of Bourns, Inc.
 "TBU" is a registered trademark of Bourns, Inc. in the U.S., Taiwan and European Community.
 Specifications are subject to change without notice.
 Customers should verify actual device performance in their specific applications.