

**BOURNS®**

## Features

- Patented (MSP®) Multi-Stage Protection
- Balanced TRIGARD®
- Self-resetting low resistance sneak current protection with Bourns® PPTC resistors
- Patented Switch-Grade Fail-Short device
- Quick response and high energy handling
- UL Listing per UL497 (File E53117)
- Sealed option for harsh environments
- Meets test requirements of GR 974, GR 1361, SBC SR 5165 and RUS PE-80
- Telcordia Analysis report DA-1547
- Ideal for high-speed networks in high-exposure environments
- Solid brass, gold-plated pins
- Test point access option

## 2430 Series 5-Pin Surge Protector

Bourns® 5-pin Model 2430 is a new generation of Bourns® telecommunications protectors for superior performance and long life. The 2430 series protector provide highly reliable overvoltage and self-resetting sneak current protection for copper pair voice-band and high speed data circuits. The Bourns® MSP® device combines the advantages of gas tube and solid state protection, while integrating three advanced technologies: a proprietary high-efficiency gas discharge tube, precision matched metal oxide varistors and a patented Switch-Grade Fail-Short mechanism. The unique Switch-Grade Fail-Short mechanism ensures superior thermal protection with fast acting, highly reliable response to thermal overload conditions. This combined technology provides lower capacitance, higher reliability and longer life than competitive hybrid technologies. Bourns® Multifuse® PPTCs are used for sneak current protection providing reliable and self-resetting performance with less than four ohms of resistance.

Bourns® 2430 protectors can be used universally for broadband voice and data circuits including ADSL, ADSL2+, VDSL, VDSL2 and high-speed Ethernet. The 2430 series is an innovative, superior choice for 5 pin protection of copper pair circuits.

### Characteristics

Test methods per UL 497, CSA C22.2, Telcordia GR 974, 1361 and SBC SR 5165.

DC Breakdown .....	300-400 V
AC Breakdown @ 60 Hz .....	300-400 V
Impulse Breakdown	
100 V/μs .....	600 V
1000 V/μs .....	650 V
Insulation Resistance @ 100 Vdc .....	> 1 GΩ
Insertion Loss @ 100 MHz .....	< 1.0 dB <sup>1</sup>
Return Loss @ 100 MHz .....	> 14 dB <sup>1</sup>
Capacitance Tip to Ring @ 1 MHz .....	12 pF typical
Capacitance Tip or Ring to Ground @ 1 MHz .....	23 pF typical
Impulse Reset <sup>5</sup>	
52 V, 260 mA .....	< 10 ms <sup>2</sup>
135 V, 200 mA .....	< 10 ms <sup>2</sup>
150 V, 200 mA .....	< 150 ms
Impulse Life Characteristics (Tip and Ring to Ground Simultaneously)	
10 A to 100 A, 10/1000 μs .....	> 3000 operations <sup>2</sup>
300 A, 10/1000 μs .....	> 1000 operations <sup>2</sup>
500 A, 10/1000 μs .....	> 1000 operations <sup>4</sup>
2,000 A, 10/250 μs .....	> 100 operations <sup>2</sup>
5,000 A, 20/100 μs .....	> 10 operations <sup>2</sup>
20,000 A, 8/20 μs .....	> 10 operations <sup>4</sup>
AC Life Characteristics (Tip and Ring to Ground Simultaneously)	
0.5 A rms continuous .....	> 30 seconds
1 A rms, 1 second, 600 ft. cable .....	> 60 operations
1 A rms, 1 second, 1 mile cable .....	> 60 operations
10 A rms, 1 second .....	> 5 operations
65 A rms, 11 cycles .....	> 1 operation <sup>3</sup>
120 A rms, 0.1 second .....	1 operation
High Current Capability and Thermal Operation (T/R to Ground) .....	> 30 Arms, simultaneously
Storage and Operating Temperature .....	-55 to +85 °C
Sneak Current Characteristics	
Resistance (No Heat Coil Inductance) .....	< 4 ohms
Transition Current @ -40 °C (800 mA), +20 °C (540 mA), +65 °C (300 mA) .....	< 210 seconds
Rated Current @ -40 °C (100 mA), +20 °C (100 mA), +65 °C (100 mA) .....	> 3 hours
Impulse Life 10 x 1000 μs @ -40 °C, +20 °C, +65 °C .....	25 A ELTGS

Telcordia analyzed for controlled (non-sealed) and uncontrolled high exposure (sealed) environments per GR 974 and SBC SR 5165. Please refer to Telcordia Analysis Report DA-1547 Volumes 1 and 2.

### Notes:

<sup>1</sup> Tested according to Category 5 requirements

<sup>2</sup> Exceeds Telcordia (Bellcore) GR 1361

<sup>3</sup> Surpasses Telcordia GR 974

<sup>4</sup> RUS (REA) PE-80

<sup>5</sup> Network applied

Line to Line voltage is approximately 1.8 to 2 times the stated Line to Ground breakdown voltage.

Specifications are subject to change without notice.  
Customers should verify actual device performance in their specific applications.

# 2430 Series 5-Pin Surge Protector

**BOURNS®**

## Product Dimensions

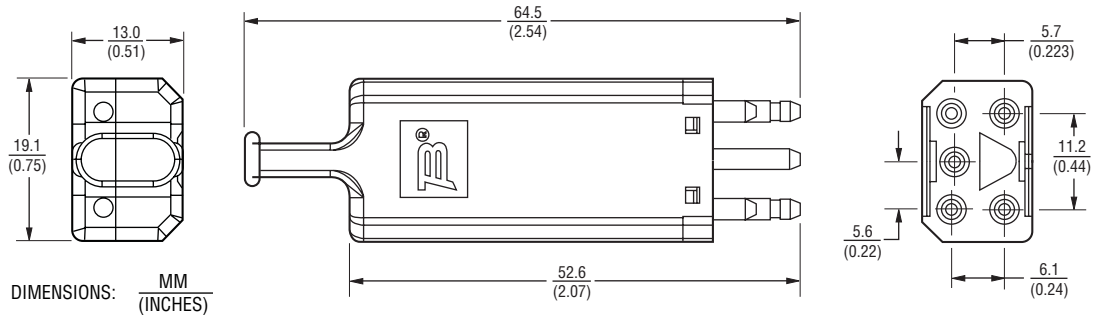

## Schematic

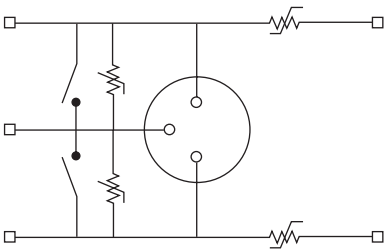

## How To Order

**2430 - 4 xx - x - xx - xx**

**Model Number Designator** \_\_\_\_\_

**Overcurrent Protection** \_\_\_\_\_

**Housing Color** \_\_\_\_\_

- 1 = Black
- 3 = Red
- 6 = Blue
- 7 = Violet
- 9 = Orange
- 10 = Yellow

**Pin Plating** \_\_\_\_\_

- G = Gold Plated
- N = Tin Plated (Ground pin is tin plated on all models)

**MOV Balance** \_\_\_\_\_

- Blank = Standard MSP®
- BC = Balanced Capacitance\*

**Housing Options** \_\_\_\_\_

- S = Sealed
- T = Test Points
- ST = Sealed and Test Points

**Examples:**

2430-41-G-T = Black housing, gold-plated pins, standard MSP®, 4 ohm, test points  
 2430-43-N-BC = Red housing, tin-plated pins, balanced capacitance MSP®, 4 ohm

\*For use on DSL Systems that require balanced capacitance of  $\leq 1$  pF.

**BOURNS®**

**Asia-Pacific:** Tel: +886-2 2562-4117 • Fax: +886-2 2562-4116

**Europe:** Tel: +41-41 768 5555 • Fax: +41-41 768 5510

**The Americas:** Tel: +1-951 781-5500 • Fax: +1-951 781-5700

[www.bourns.com](http://www.bourns.com)